



## INSTALLATION INSTRUCTIONS FOR PART 95-7331

### APPLICATIONS

# KIA Amanti 2007-2008

## 95-7331

### KIT FEATURES

- Double DIN Radio Provision
- Stacked ISO Mount Units Provision

### KIT COMPONENTS

A) Radio Housing B) Double DIN Brackets

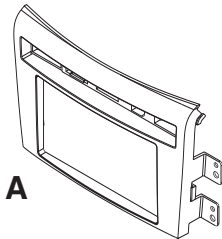

A

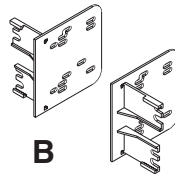

B

### TOOLS REQUIRED:

- Small Flat Blade Screwdriver/ Panel Removal Tool
- Phillips Screwdriver
  - Socket set



1-800-221-0932



[www.metraonline.com](http://www.metraonline.com)

© COPYRIGHT 2007-2008

METRA ELECTRONICS CORPORATION



**TABLE OF CONTENTS**

**Dash Disassembly**

**- KIA Amanti 2007-2008..... 1,2**

**Kit Assembly**

**- Double DIN Radio Provision /Stacked ISO Mount Units Provision .....3**

**Final Assembly ..... 4**

**\*Note:**

**Refer also to the instructions included with the aftermarket radio.**

**KIA AMANTI 2007-2008**

- 1** Disconnect the negative battery terminal to prevent an accidental short circuit.
- 2** Unclip the top half of the shift knob and remove the "C" clip securing the shifter. Pull up on shifter to remove. (Figure A)
- 3** Unclip and remove the panel surrounding the shifter. (Figure B)
- 4** Unclip and remove top half of center console including the cup holders. (Figure C)
- 5** Open center console and remove screw cover in bottom. (Figure D)
- 6** Remove (2) 10 MM bolts securing compartment then unclip and remove the compartment. (Figure D)

*Continue to kit assembly.*

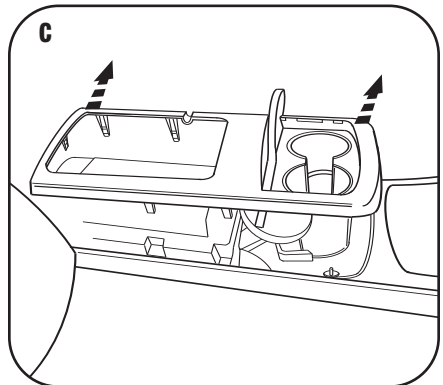
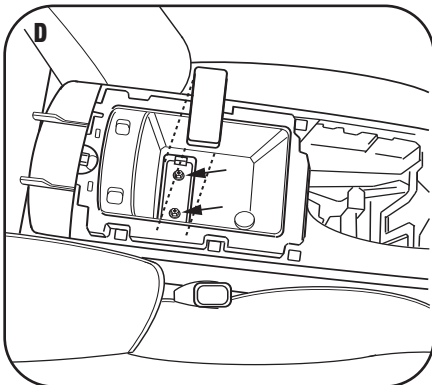
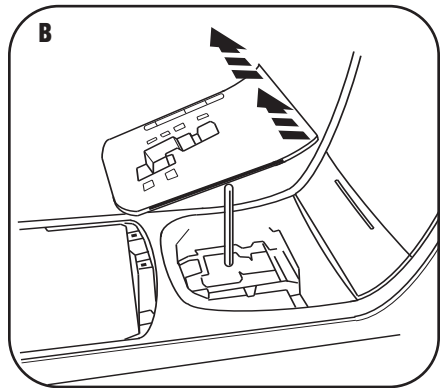
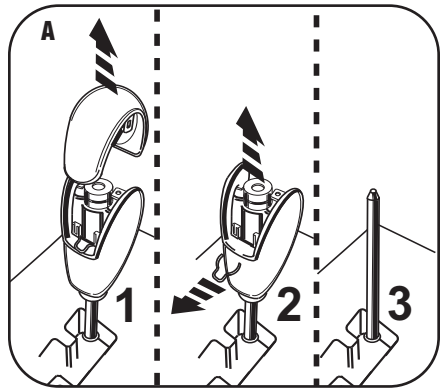

## KIA AMANTI 2007-2008

- 7 Unclip the rear trim panel from the center console including a/c vents. Unplug and remove the rear trim panel. (Figure E)
- 8 Remove (1) Phillips screw from each side at the rear of the center console. (Figure E)
- 9 Unclip the side panels from the front of the center console. It is not necessary to remove these panels. (Figure F)
- 10 Remove (4) Phillips screws securing center console then lift and slide the center console back out of the way.  
**Note:** You do not have to take the center console all the way out. (Figure G)
- 11 Remove (1) Phillips screw from each side panel then unclip and remove the side panels. (Figure H)
- 12 Remove (4) Phillips screws securing the radio. Unplug and remove the radio.
- 13 Unclip and remove the switches and/or switch covers along the top of the factory radio. (**Retain switches and/or covers to be reinstalled in the radio housing.**)

Continue to kit assembly.

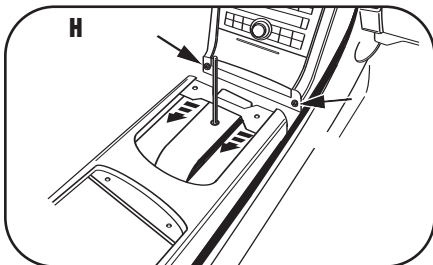
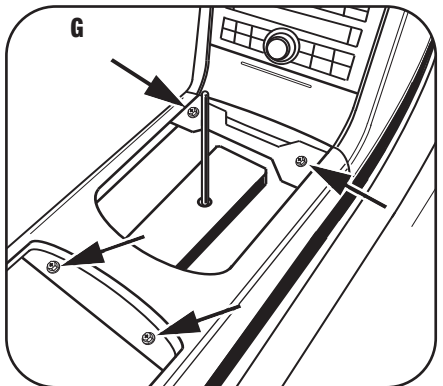
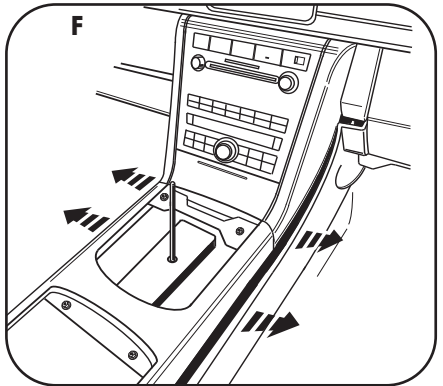
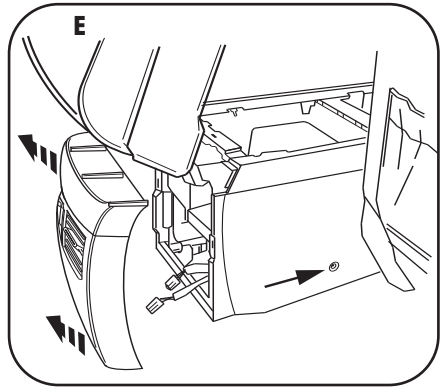

## DOUBLE DIN RADIO PROVISION STACKED ISO MOUNT UNITS PROVISION

*\*Note: Refer also to the instructions included with the aftermarket radio.*

- 1** Snap the switches into the radio housing in the same location as removed from the factory radio. (Figure A)
- 2** Snap the Double DIN brackets to the inside edge of the Radio Housing. (Figure B)
- 3** Slide the Double DIN Radio or stacked ISO Mount units into the bracket/radio housing assembly and secure to the assembly using the screws supplied with the radio or ISO mount units. (Figure C)

*Continue to final assembly.*

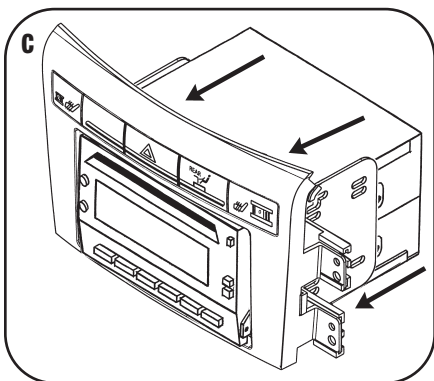
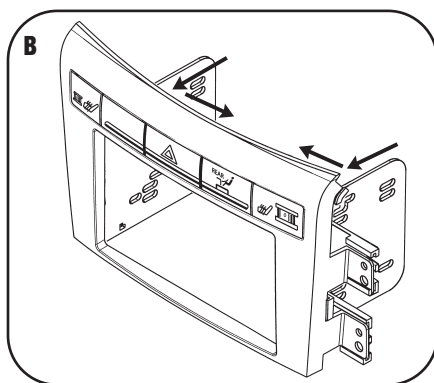
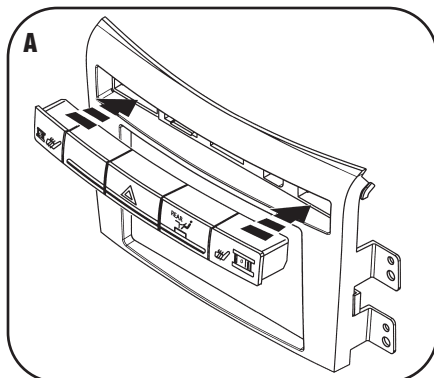

# FINAL ASSEMBLY

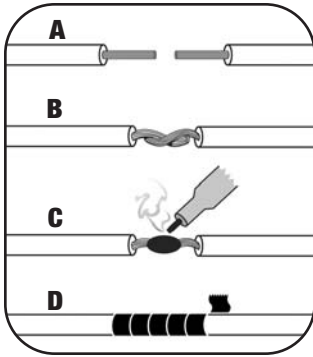

**(A) Strip wire ends back 1/2"**

**B) Twist ends together**

**C) Solder**

**D) Tape**

- 1 Locate the factory wiring harness in the dash. Metra recommends using the proper mating adapter and making connections as shown. (Isolate and individually tape off the ends of any unused wires to prevent electrical short circuit.)
- 2 Re-connect the negative battery terminal and test the unit for proper operation.
- 3 Reassemble radio and dash assemblies in reverse order of disassembly.

## FINAL WIRING CONNECTIONS

Make wiring connections using the EIA color code chart shown below and the instructions included with the head unit. Metra recommends making connections as shown below; Strip, Splice, Solder, Tape. Isolate and individually tape off ends of any unused wires to prevent electrical short circuit.

### METRA / EIA WIRING CODE

12V Ignition / Acc. . . . . Red	Right Front (+) . . . . . Gray
12V Batt / Memory . . . . . Yellow	Right Front (-) . . . . . Gray/ Black
Ground . . . . . Black*	Left Front (+) . . . . . White
Power Antenna . . . . . Blue	Left Front (-) . . . . . White / Black
Amp Turn-On . . . . . Blue / White	Right Rear (+) . . . . . Violet
Amp Ground . . . . . Black / White	Right Rear (-) . . . . . Violet / Black
Illumination . . . . . Orange	Left Rear (+) . . . . . Green
Dimmer . . . . . Orange / White	Left Rear (-) . . . . . Green / Black

\*NOTE: When a Black wire is not present, ground radio to vehicle chassis.  
All colors may not be present on all leads due to manufacturer's specifications.



**NOTES**

A series of 20 horizontal lines for writing notes, spaced evenly down the page.

# 95-7331 INSTRUCTIONS



**1-800-221-0932**



**[www.metraonline.com](http://www.metraonline.com)**

REV. 02/26/08 © COPYRIGHT 2007-2008 METRA ELECTRONICS CORPORATION INST95-7331