



INSTALLATION INSTRUCTIONS FOR PART 95-8223

APPLICATIONS

Toyota Corolla 2009

95-8223

KIT FEATURES

- Double DIN Radio Provision
- Stacked ISO Mount Units Provision



KIT COMPONENTS

- A) Radio Housing Trim Plate
- B) Double Din Trim Plate

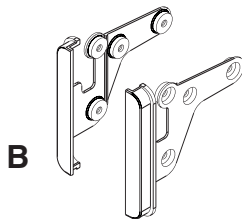
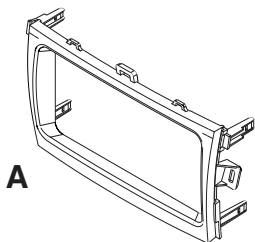

TOOLS REQUIRED:

- Small Flat Blade Screwdriver/ Panel Removal Tool
- Phillips Screwdriver

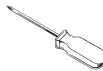
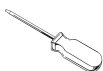

1-800-221-0932



www.metraonline.com

© COPYRIGHT 2008 METRA ELECTRONICS CORPORATION



TABLE OF CONTENTS

Dash Disassembly

- Toyota Corolla 2009 1

Kit Assembly

- Double DIN/Stacked ISO Mount Units Provision 2

Final Assembly 3

***Note:**

Refer also to the instructions included with the aftermarket radio.

Toyota Corolla 2009

- 1** Disconnect the negative battery terminal to prevent an accidental short circuit.
- 2** Unclip and remove the (4) side trim panels from the right and left side of the radio and a/c controls. (Figure A)
- 3** Unclip and remove the a/c vent panel above the factory radio.(Figure B)
- 4** Remove (4) 10 MM bolts securing the radio. (Figure C)
- 5** Remove (8) screws securing the brackets to the factory radio and remove the brackets. (Retain the brackets for re-use during kit assembly.) (Figure D)
- 6** Remove (4) plastic clips from the back of the factory radio. (Retain the clips for re-use during kit assembly.)

Continue to kit assembly.

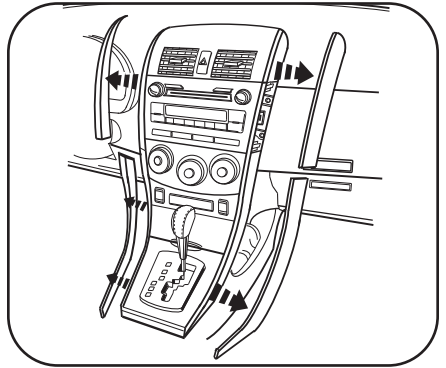
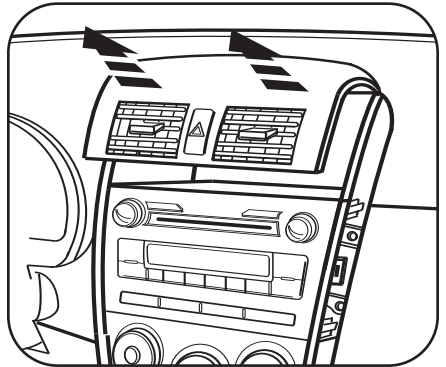
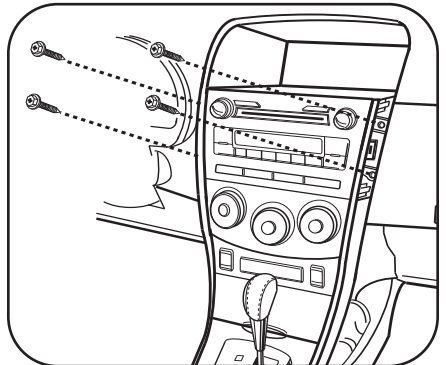
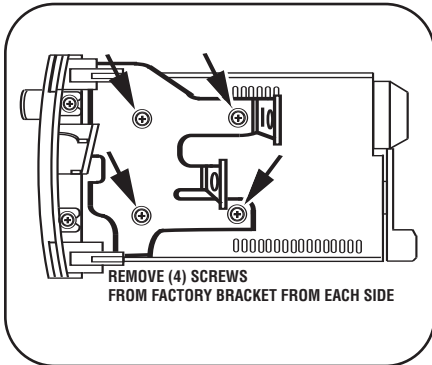
A

B

C

D

DOUBLE DIN/STACKED ISO MOUNT UNITS PROVISION

**Note: Refer also to the instructions included with the aftermarket radio.*

- 1 Attach the clips removed from the factory radio to the back of the radio housing trim plate. (Figure A)
- 2 Attach the factory mounting brackets and the Double DIN trim plates to the Double DIN or the stacked ISO mount unit(s) using the screws supplied with the unit(s). (Figure B)

Continue to final assembly.

A

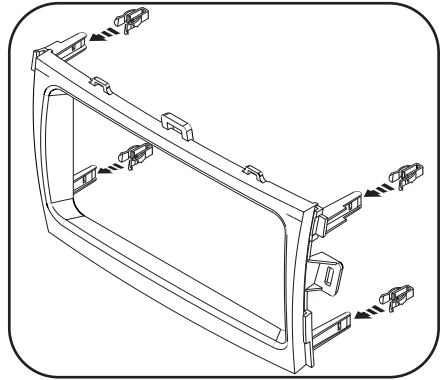

B

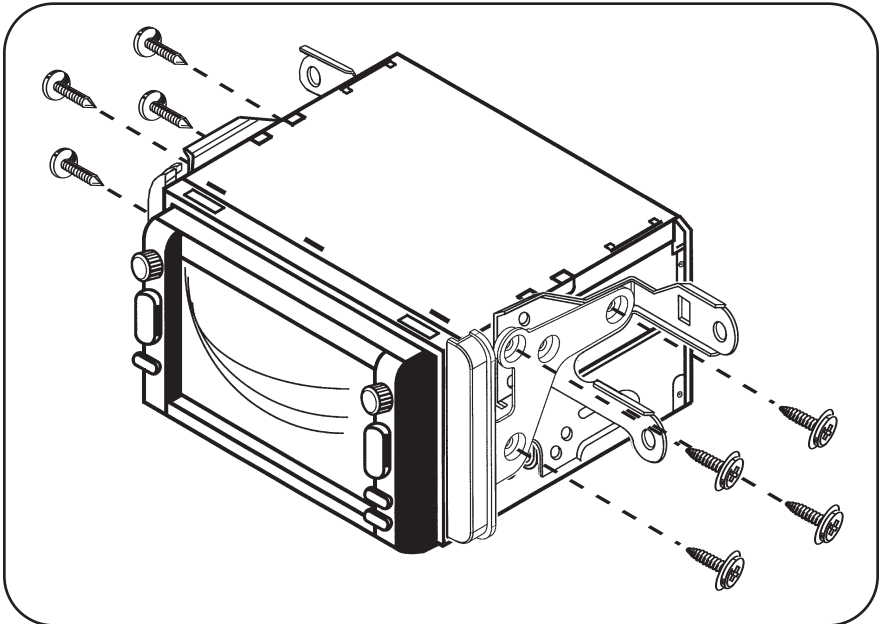

FINAL ASSEMBLY

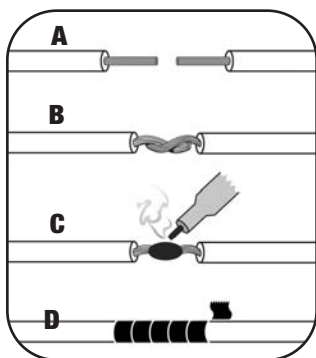

- (A) Strip wire ends back 1/2"**
- B) Twist ends together**
- C) Solder**
- D) Tape**

- 1** Locate the factory wiring harness in the dash. Metra recommends using the proper mating adapter and making connections as shown. (Isolate and individually tape off the ends of any unused wires to prevent electrical short circuit.)
- 2** Re-connect the negative battery terminal and test the unit for proper operation.
- 3** Reassemble in reverse order of disassembly using the 95-8223 Radio Housing Trim Plate in place of the factory radio trim panel.

FINAL WIRING CONNECTIONS

Make wiring connections using the EIA color code chart shown below and the instructions included with the head unit. Metra recommends making connections as shown below; Strip, Splice, Solder, Tape. Isolate and individually tape off ends of any unused wires to prevent electrical short circuit.

METRA / EIA WIRING CODE

12V Ignition / Acc. Red	Right Front (+) Gray
12V Batt / Memory Yellow	Right Front (-) Gray/ Black
Ground Black*	Left Front (+) White
Power Antenna Blue	Left Front (-) White / Black
Amp Turn-On Blue / White	Right Rear (+) Violet
Amp Ground Black / White	Right Rear (-) Violet / Black
Illumination Orange	Left Rear (+) Green
Dimmer Orange / White	Left Rear (-) Green / Black

***NOTE:** When a Black wire is not present, ground radio to vehicle chassis.
All colors may not be present on all leads due to manufacturer's specifications.

95-8223 INSTRUCTIONS



1-800-221-0932



www.metraonline.com

REV. 05/13/08 © COPYRIGHT 2004-2008 METRA ELECTRONICS CORPORATION INST95-8223