

KIT FEATURES

- ▶ Shaft and DIN unit provisions

KIT COMPONENTS

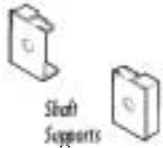

TOOLS REQUIRED



99-3100 AW-310SA INSTALLATION INSTRUCTIONS

APPLICATIONS

CAR	PAGE
SATURN (All models) 1995-99.....	1-2



ALL VEHICLES

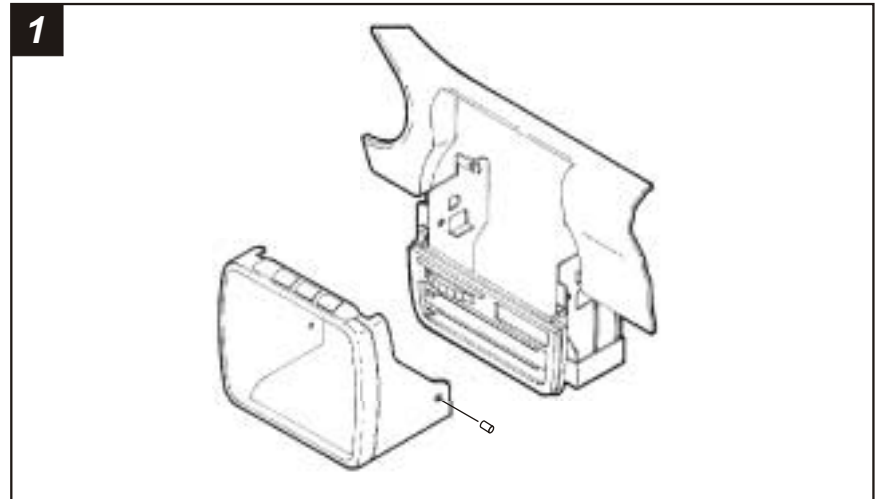

Disconnect the negative battery terminal to prevent an accidental short circuit. Remove (2) pop-clips from the sides of the radio trim bezel. Unclip the radio trim bezel, disconnect the switch wiring and remove the bezel. Remove (2) 7mm hex-head screws securing the top of the factory head unit and disconnect the wiring.

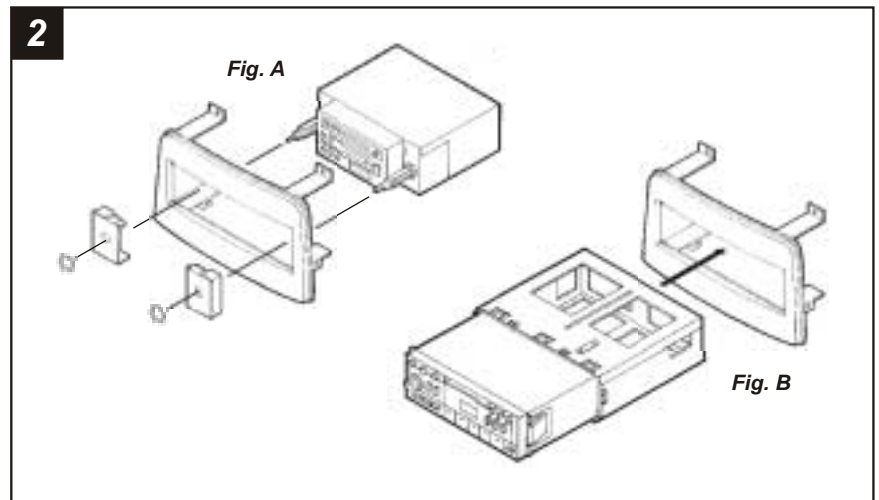

2-SHAFT HEAD UNITS: Snap the **Shaft Supports** into the **Radio Housing**. Slide the aftermarket head unit into the kit and secure with shaft nuts. (see Fig. A)

DIN HEAD UNITS: Slide the DIN cage into the kit and secure by bending the metal locking tabs down. Slide the aftermarket head unit into the cage until secure. (see Fig. B)

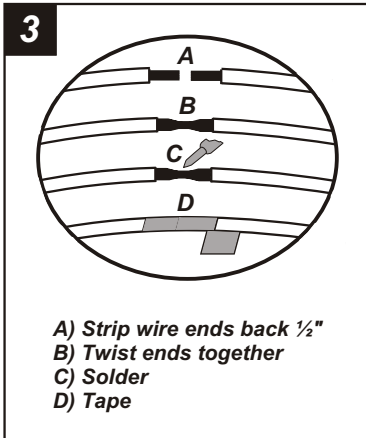

Locate the factory wiring harness in the dash. Metra recommends using the proper mating adaptor and making connections as shown. (Isolate and individually tape off the ends of any unused wires to prevent electrical short circuit).

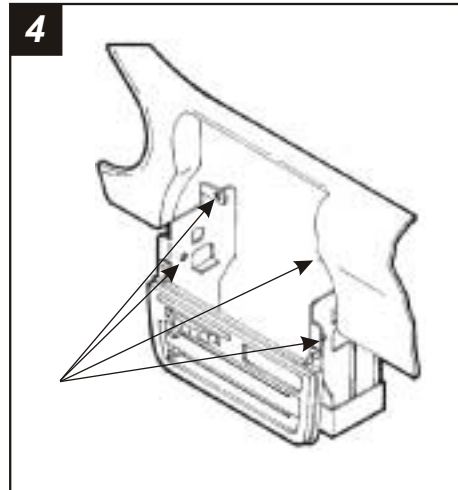

Locate the (4) mounting locations in the sub-dash.

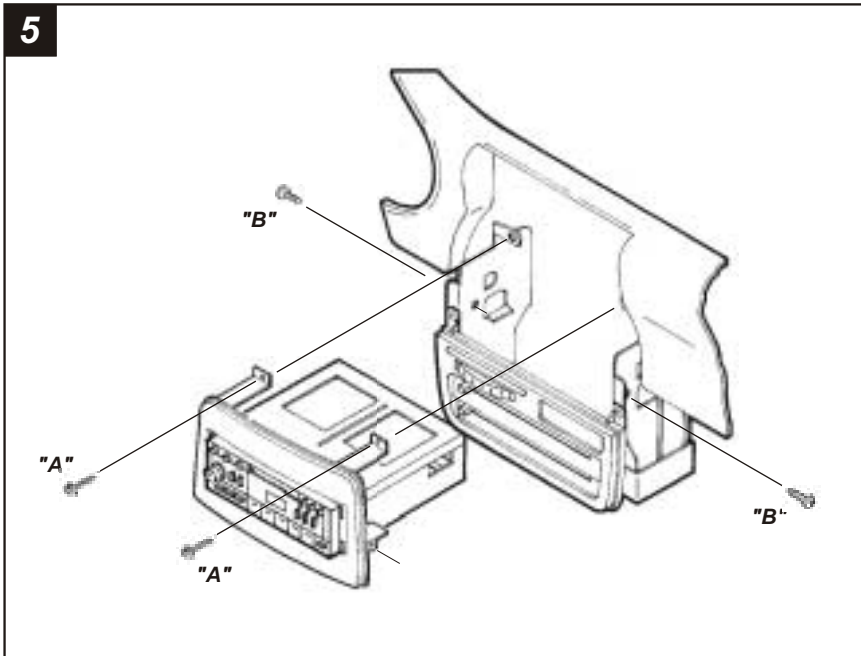

Re-connect the battery terminal and test the unit for proper operation. Mount the head unit/kit assembly to the sub-dash with (2) 7mm hex-head screws previously removed in step #1 ("A") and (2) #10 Phillips screws supplied ("B").