



## INSTALLATION INSTRUCTIONS FOR PART 99-7010

### APPLICATIONS 2006 Mitsubishi Eclipse

# 99-7010



#### KIT FEATURES

- DIN Head unit provision with pocket
- ISO DIN Head unit provision with pocket
- DDIN Head unit provision
- ISO Stacked Head unit provision

#### KIT COMPONENTS

A) Radio Housing B) ISO Brackets C) ISO Trim Plate D) DDIN Brackets E) Pocket F) DDIN Trim Plate

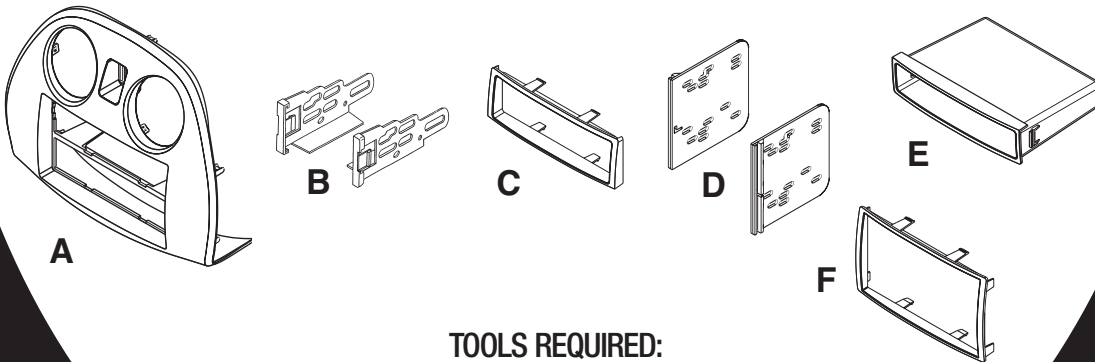

#### TOOLS REQUIRED:

Phillips Screwdriver | Small Flat Blade Screwdriver



1-800-221-0932



[www.metraonline.com](http://www.metraonline.com)

© COPYRIGHT 2004 METRA ELECTRONICS CORPORATION



# **TABLE OF CONTENTS**

---

***Dash Disassembly***

***2006 Mitsubishi Eclipse ..... 1***

***Radio Housing Assembly ..... 2***

***Kit Assembly ..... 3, 4***

***Final Assembly ..... 5***

## 2006 MITSUBISHI ECLIPSE

- 1 Disconnect the negative battery terminal to prevent an accidental short circuit.
- 2 Unclip and remove the trim panel including the radio a/c vents (Figure A)
- 3 Remove (4) Phillips screws securing radio chassis to dash to remove. (Figure B)
- 4 Unclip and remove the a/c vents from the factory radio trim panel. (Figure C)
- 5 Unclip and remove the hazard switch from the factory radio trim panel. (Figure D)

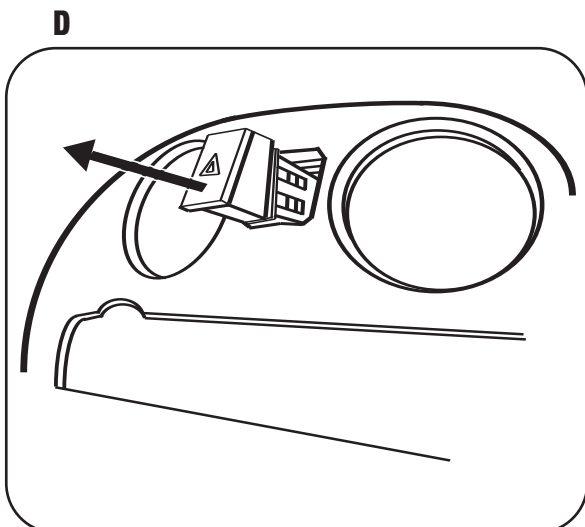
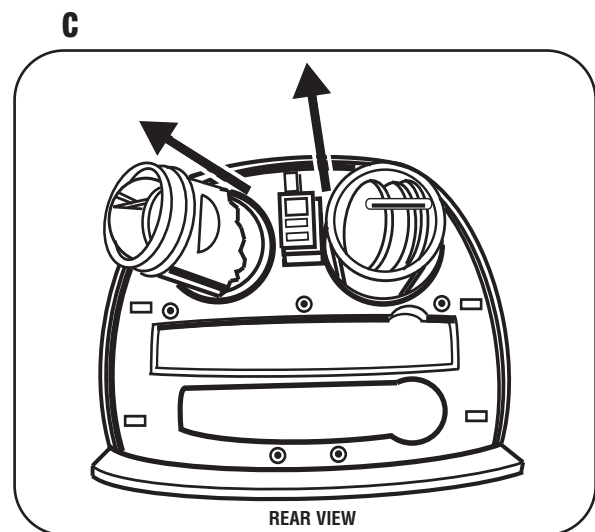
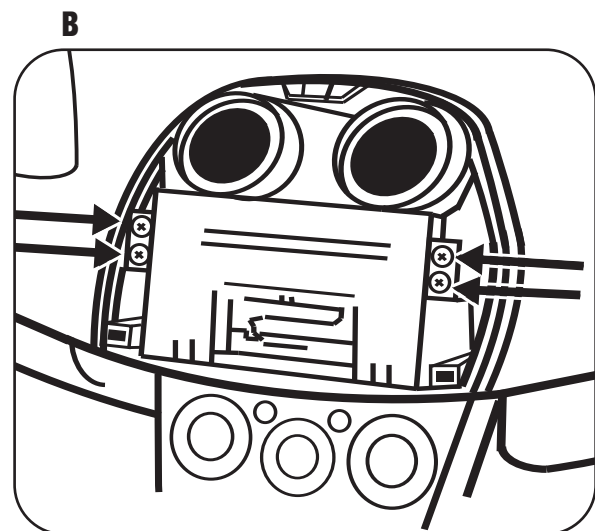
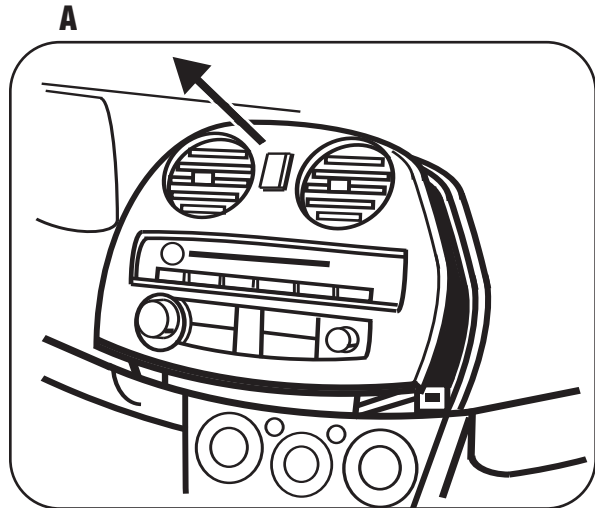

## RADIO HOUSING ASSEMBLY

- 1** Clip the a/c vents into the 99-7010 radio housing. (Figure A)
  
- 2** Clip the hazard switch into the 99-7010 radio housing. (Figure B)

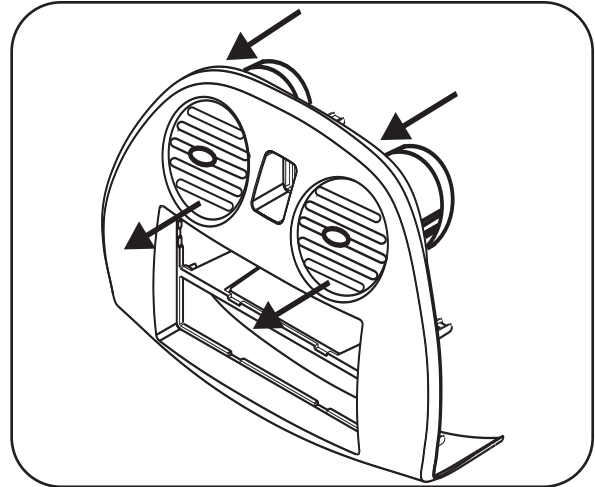
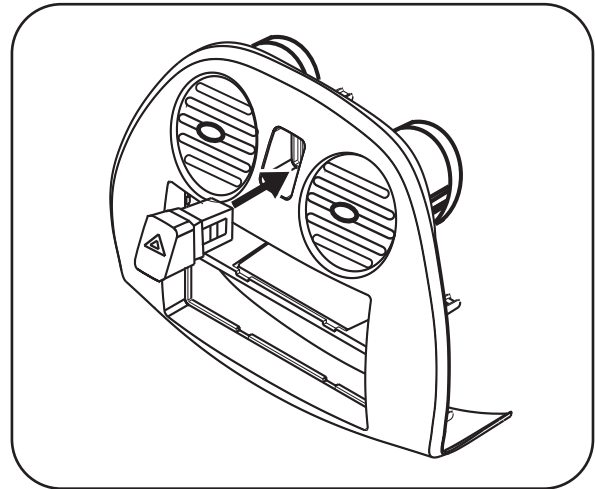
**A**

**B**

## DIN HEAD UNIT PROVISION

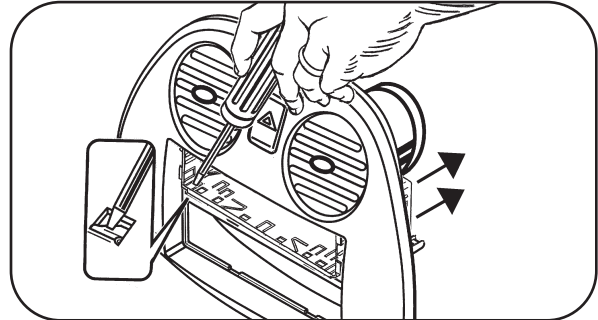
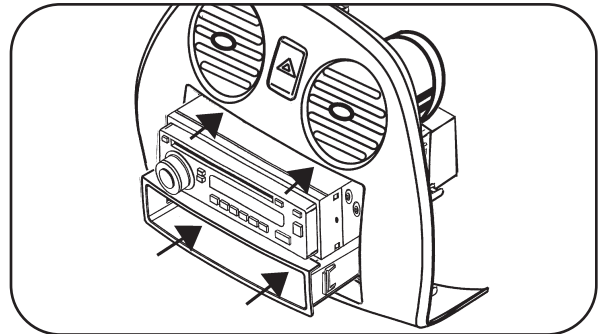
- 1 Slide the DIN cage into the Radio Housing and secure by bending the metal locking tabs down. (Figure A)
- 2 Slide the aftermarket head unit into the cage and secure. (Figure B)
- 3 Snap the pocket into the radio housing. (Figure B)

**A****B**

## ISO DIN HEAD UNIT PROVISION

- 1 Mount the ISO Brackets to the head unit with the screws supplied with the unit. (Figure A)
- 2 Slide the head unit into the radio opening until the side clips engage. (Figure B)
- 3 Snap the ISO Trim Plate into the Radio Housing. (Figure B)
- 4 Snap the pocket into the radio housing. (Figure B)

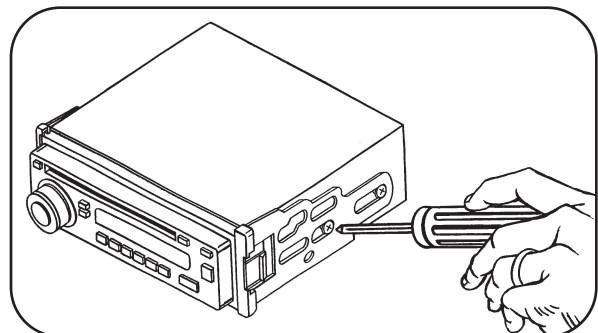
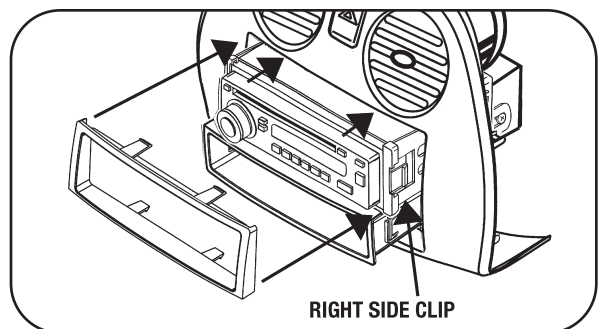
**A****B**

## DOUBLE DIN HEAD UNIT PROVISION

- 1 Cut the center bar rib.
- 2 Slide the appropriate bracket into the radio housing aligning the holes in the radio housing with the holes on the bracket. (Figure A)
- 3 Slide the DDIN radio unit into the DDIN bracket/radio housing assembly and secure the unit to the kit using the screws supplied with the head unit. (Figure B)
- 4 Snap the DDIN Trim Plate into the radio housing. (Figure B)

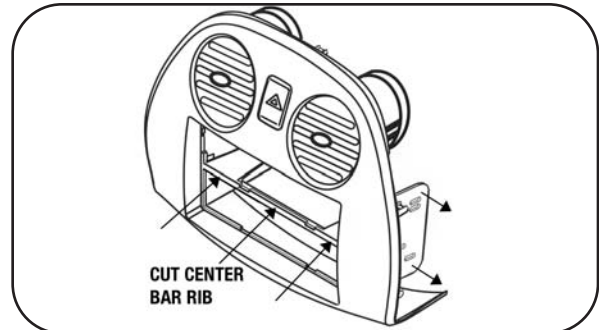
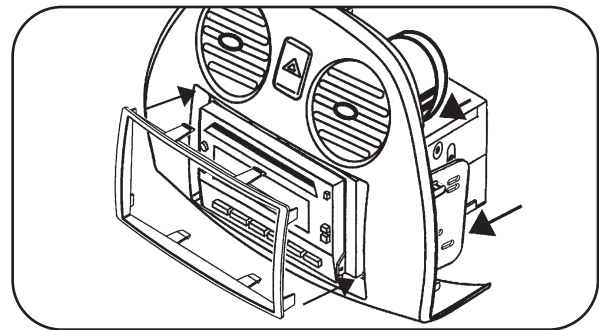
**A****B**

## STACKED ISO DIN HEAD UNIT PROVISION

- 1 Cut the center bar rib.
- 2 Slide the appropriate bracket into the radio housing aligning the holes in the radio housing with the holes on the bracket. (Figure A)
- 3 Slide the stacked ISO DIN units into the DDIN bracket/radio housing assembly and secure the units to the kit using the screws supplied with the head units. (Figure B)
- 4 Snap the DDIN Trim Plate into the radio housing. (Figure B)

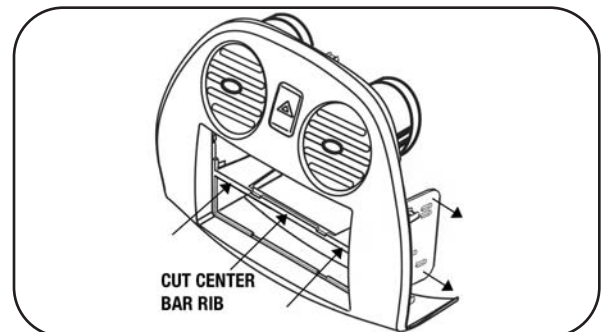
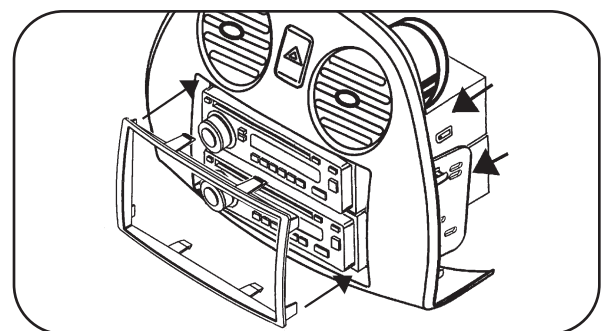
**A****B**

## FINAL ASSEMBLY

- 1 Locate the factory wiring harness in the dash and make the connection as shown. Metra recommends using the proper mating adapter and making the connections as shown. (Isolate and individually tape off the ends of any unused wires to prevent electrical short circuit.)
- 2 Re-connect the negative battery terminal and test the unit for proper operation.
- 3 Reassemble radio and dash assemblies in reverse order of disassembly.

### FINAL WIRING CONNECTIONS

Make wiring connections using the EIA color code chart shown below and the instructions included with the head unit. Metra recommends making connections as shown below; Strip, Splice, Solder, Tape. Isolate and individually tape off ends of any unused wires to prevent electrical short circuit.

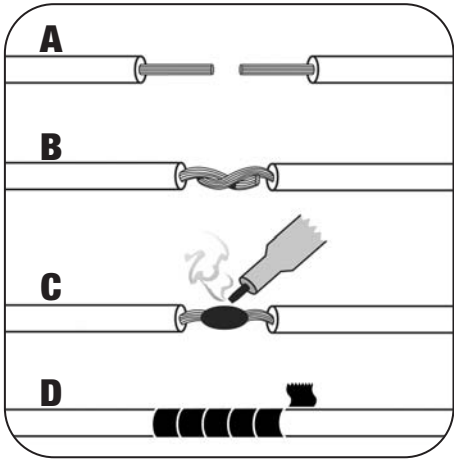

- A) Strip wire ends back 1/2"**
- B) Twist ends together**
- C) Solder**
- D) Tape**

### METRA / EIA WIRING CODE

12V Ignition / Acc . . . Red	Right Front (+) . . . . . Gray
12V Batt / Memory . . Yellow	Right Front (-) . . . . . Gray / Black
Ground . . . . . Black*	Left Front (+) . . . . . White
Power Antenna . . . . . Blue	Left Front (-) . . . . . White / Black
Amp Turn-On . . . . . Blue / White	Right Rear (+) . . . . . Violet
Amp Ground . . . . . Black / White	Right Rear (-) . . . . . Violet / Black
Illumination . . . . . Orange	Left Rear (+) . . . . . Green
Dimmer . . . . . Orange / White	Left Rear (-) . . . . . Green / Black

**\*NOTE:** When Black a wire is not present, ground radio to vehicle chassis.  
 All colors may not be present on all leads due to manufacturer's specifications.

# 99-7010 INSTRUCTIONS



**1-800-221-0932**



**[www.metraonline.com](http://www.metraonline.com)**

REV. 12/22/05

© COPYRIGHT 2004 METRA ELECTRONICS CORPORATION

INST99-7010