

4

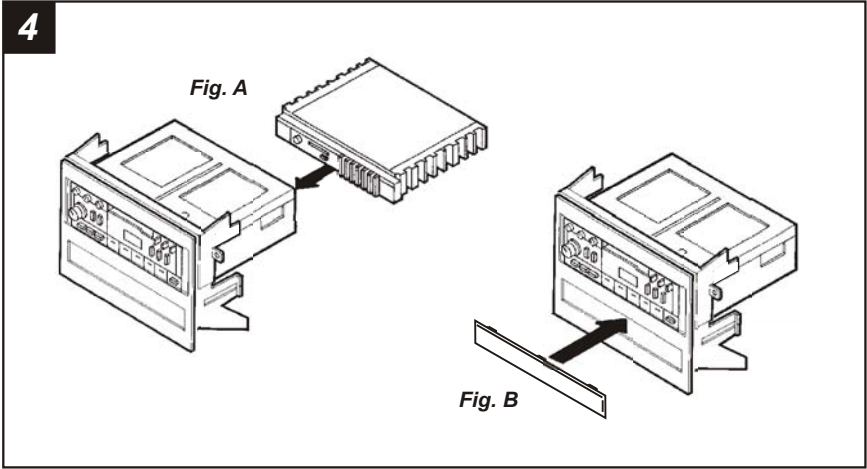

IF AN EQUALIZER WILL BE INCLUDED: Slide the aftermarket equalizer into the back of the **Radio Housing**. Using the hardware included with the equalizer, mount the unit to the kit. (see Fig. A)

IF AN EQUALIZER WILL NOT BE INCLUDED: Snap the **Equalizer Dummy Plate** into the **Radio Housing**. (see Fig. B)

5

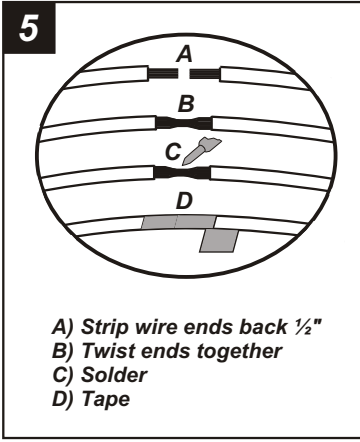

Locate the factory wiring harness in the dash. Metra recommends using the proper mating adaptor and making connections as shown. (Isolate and individually tape off the ends of any unused wires to prevent electrical short circuit).

6

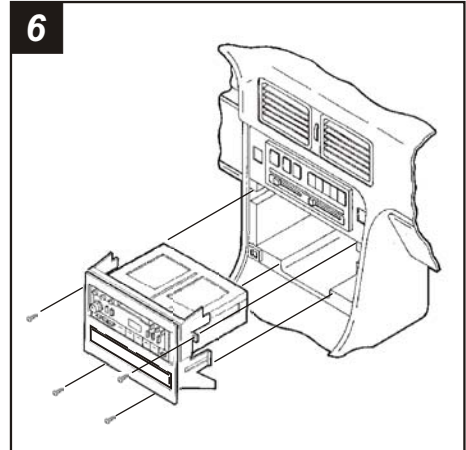

Re-connect the battery terminal and test the unit for proper operation. Mount the head unit/kit assembly to the sub-dash with (4) screws previously removed in step #1.

KIT FEATURES

- ▶ Shaft and DIN unit provisions
- ▶ Equalizer provisions

KIT COMPONENTS

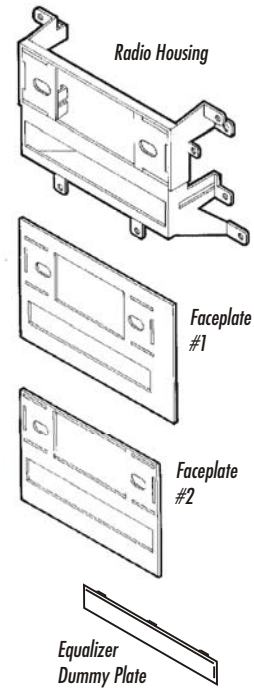

TOOLS REQUIRED



99-7407

INSTALLATION INSTRUCTIONS

APPLICATIONS

CAR	PAGE
NISSAN	
240SX 1989-94.....	1
Maxima 1989-94.....	1
Stanza 1987-89.....	2



NISSAN 240SX 1989-94

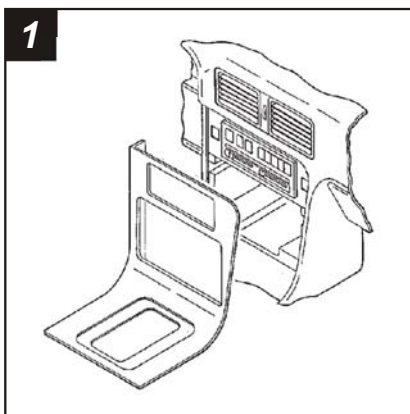

Disconnect the negative battery terminal to prevent an accidental short circuit. Unclip the gear shifter/radio trim bezel and remove the bezel. Remove (4) Phillips screws securing the factory head unit and disconnect the wiring.

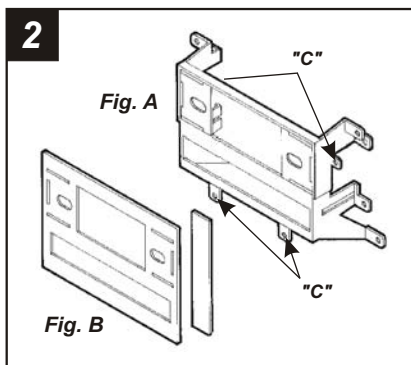

Cut and remove all mounting tabs on the **Radio Housing** EXCEPT tabs "C". The mounting tabs can be identified by the stamped letter on the back of each tab. (see Fig. A). Cut and remove the side portion of **Faceplate #1**. (see Fig. B). Skip to the *Installation Instructions for ALL VEHICLES* on Page #2.

NISSAN Stanza 1987-89

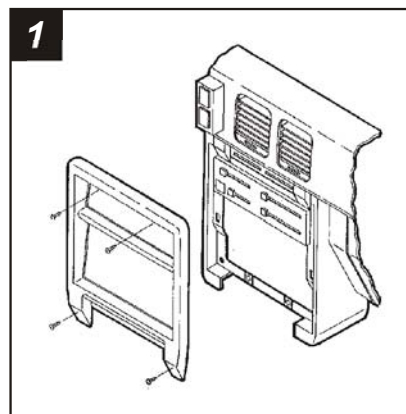

Disconnect the negative battery terminal to prevent an accidental short circuit. Remove the ashtray. Remove (2) screws from the base of the radio trim bezel. Remove (2) screws above the climate controls. Unclip the radio trim bezel and remove. Remove (4) screws securing the factory head unit and disconnect the wiring.

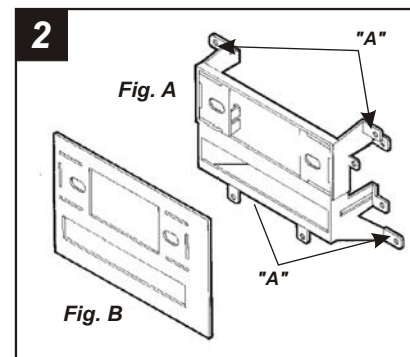

Cut and remove all mounting tabs on the **Radio Housing** EXCEPT tabs "A". The mounting tabs can be identified by the stamped letter on the back of each tab. (see Fig. A). Locate **Faceplate #1**. (see Fig. B). Skip to the *Installation Instructions for ALL VEHICLES* on Page #2.

NISSAN Maxima 1989-94

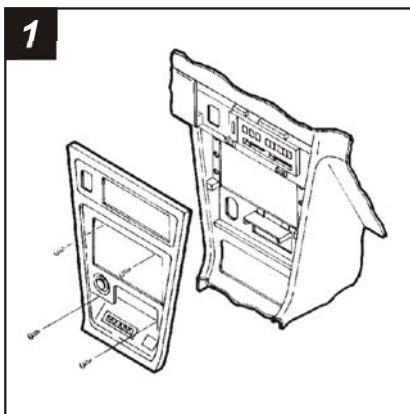

Disconnect the negative battery terminal to prevent an accidental short circuit. Remove (2) Phillips screws above the radio opening. Remove the ashtray and (2) screws exposed in the ashtray cavity. Unclip the top of the dash trim bezel and remove. Remove (4) screws securing the factory head unit and disconnect the wiring.

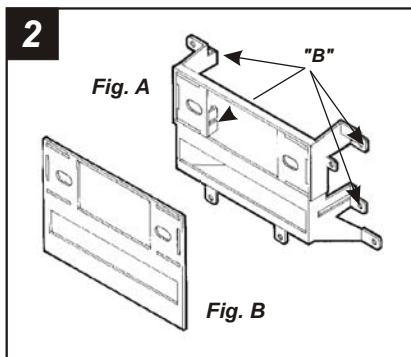

Cut and remove all mounting tabs on the **Radio Housing** EXCEPT tabs "B". The mounting tabs can be identified by the stamped letter on the back of each tab. (see Fig. A). Locate **Faceplate #2**. (see Fig. B). Skip to the *Installation Instructions for ALL VEHICLES* on Page #2.

ALL VEHICLES

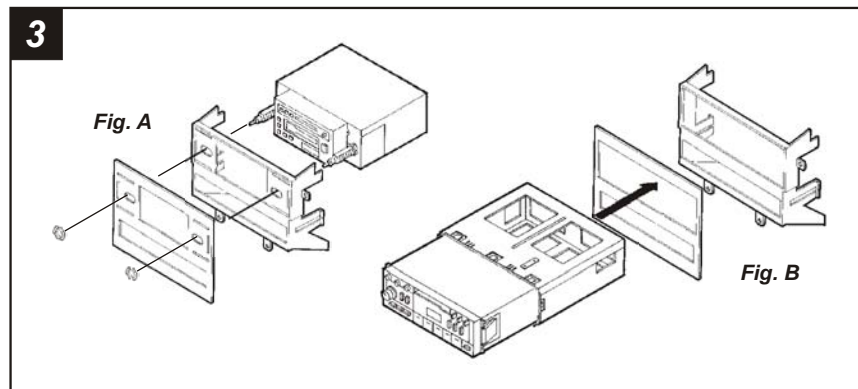

2-SHAFT HEAD UNITS: Attach the **Faceplate** to the **Radio Housing**. Slide the aftermarket head unit into the kit and secure with shaft nuts. (see Fig. A)

DIN HEAD UNITS: Cut and remove the shaft supports from the **Faceplate** and **Radio Housing**. Attach the Faceplate to the Housing. Slide the DIN cage into the kit and secure by bending the metal locking tabs down. Slide the aftermarket head unit into the cage until secure. (see Fig. B)