



INSTALLATION INSTRUCTIONS FOR PART 99-7426

APPLICATIONS

Nissan Murano 2009

(Without Bose Audio)

99-7426

KIT FEATURES

- DIN Mount Radio Provision with Pocket
- ISO Mount Radio Provision with Pocket
- Double DIN Radio Provision
- Stacked ISO Mount Units Provision
- Painted To Match OEM Finish



KIT COMPONENTS

- A) Radio Housing • B) ISO Brackets • C) ISO Trim Plate • D) Double DIN Brackets
E) Double DIN Trim Plate • F) Pocket

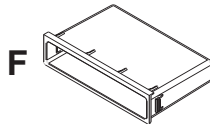
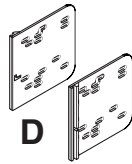
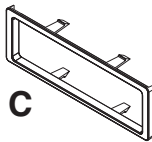
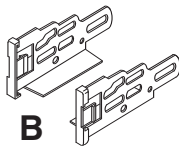
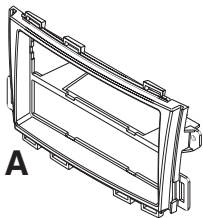

TOOLS REQUIRED:

- Small Flat Blade Screwdriver or Panel Removal Tool
- Phillips Screwdriver



1-800-221-0932



www.metraonline.com

© COPYRIGHT 2008 METRA ELECTRONICS CORPORATION



TABLE OF CONTENTS

- **Dash Disassembly**
- **Nissan Murano 2009 (Without Bose Audio)1, 2**

- **Kit Assembly:**
- **DIN Mount Radio Provision with Pocket3**
- **ISO Mount Radio Provision with Pocket4**
- **Double DIN Radio Provision5**
- **Stacked ISO Mount Units Provision.....5**

- Final Assembly6**

***Note:**

Refer also to the instructions included with the aftermarket radio.

NISSAN MURANO 2009

- 1** Disconnect the negative battery terminal to prevent an accidental short circuit.
- 2** Unclip trim panel at bottom center of dash. (Figure A)
- 3** Remove (1) Phillips screw from bottom of each side trim panel. Unclip and remove the side trim panels. (Figure B)
- 4** Remove (3) Phillips screws securing the climate control then unclip, unplug and remove it from the sub dash. (Figure C)

Continued on next page.

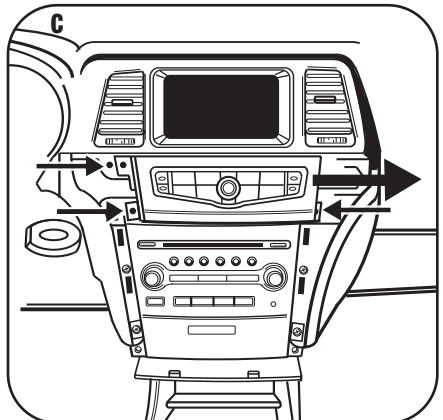
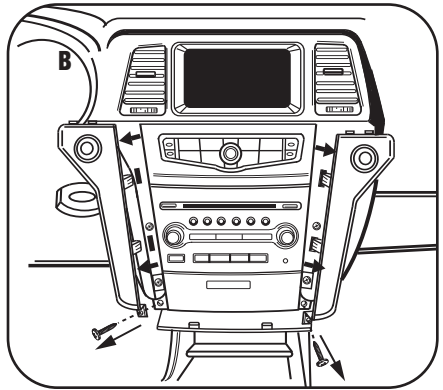
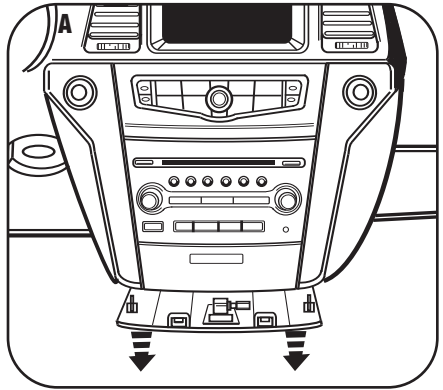

NISSAN MURANO 2009

- 5** Remove (2) Phillips screws from the panel below the radio (containing the passenger air bag light) then unclip, unplug and remove the panel. (Figure D)

- 6** Remove (6) Phillips screws securing the radio to the sub dash. Unplug and remove radio. (Figure E)

Continue to kit assembly.

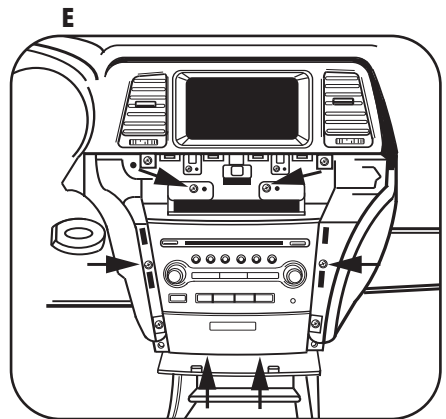
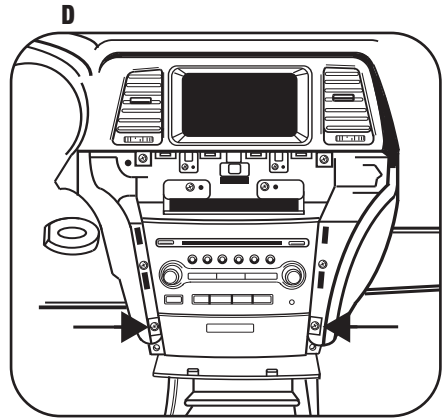

DIN MOUNT RADIO PROVISION WITH POCKET

**Note: Refer also to the instructions included with the aftermarket radio.*

- 1 Slide the DIN cage into the radio housing and secure by bending the metal locking tabs down. (Figure A)
- 2 Slide the aftermarket radio into the cage until it snaps into place. (Figure B)
- 3 Snap the pocket into the radio housing. (Figure C)

Continue to final assembly.

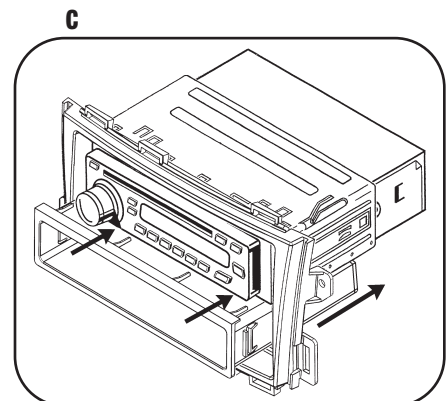
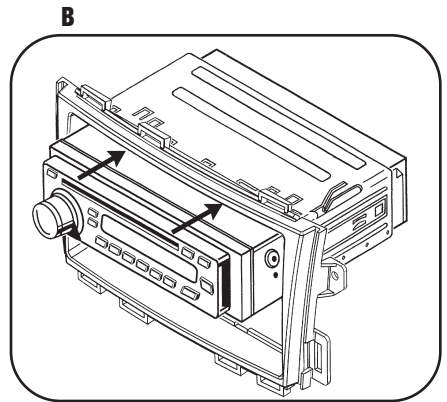
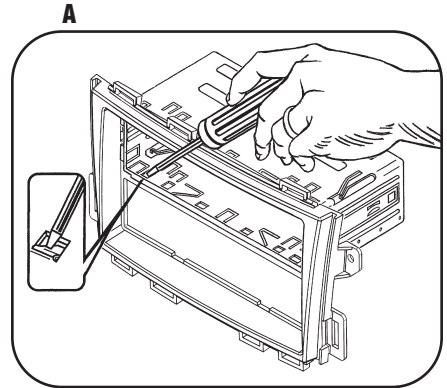

ISO MOUNT RADIO PROVISION WITH POCKET

**Note: Refer also to the instructions included with the aftermarket radio.*

- 1** Mount the ISO Brackets to the radio using the screws supplied with the radio. (Figure A)
- 2** Slide the radio into the radio housing until it snaps into place. (Figure B)
- 3** Snap the Trim plate onto the front of the Radio Housing. (Figure B)
- 4** Snap the pocket into the radio housing. (Figure C)

Continue to final assembly.

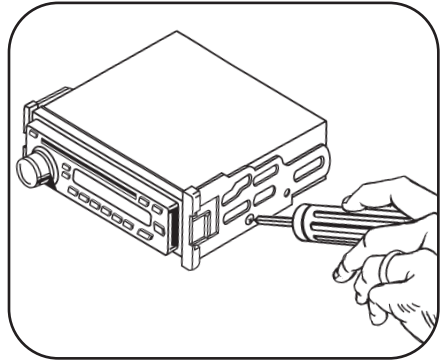
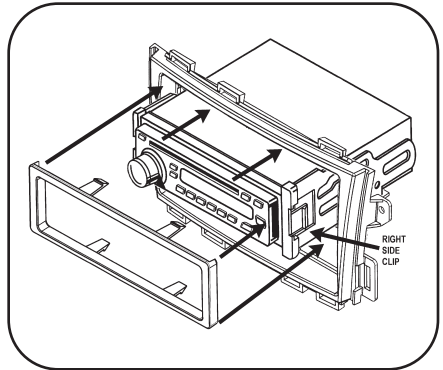
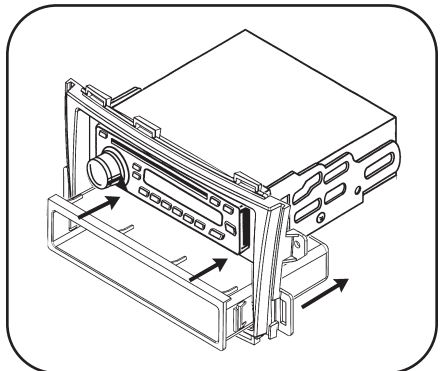
A

B

C

DOUBLE DIN RADIO PROVISION STACKED ISO MOUNT UNITS PROVISION

**Note: Refer also to the instructions included with the aftermarket radio.*

- 1** Cut and remove the center bar from the radio housing. (Figure A)
- 2** Snap the Double DIN brackets to the inside edge of the radio housing. (Figure B)
- 3** Slide the Double DIN or ISO mount unit(s) into the bracket/radio housing assembly and secure the unit(s) to the assembly using the screws supplied with the unit(s). (Figure C)
- 4** Snap the Double DIN trim plate onto the front of the radio/housing. (Figure C)

Continue to final assembly.

A

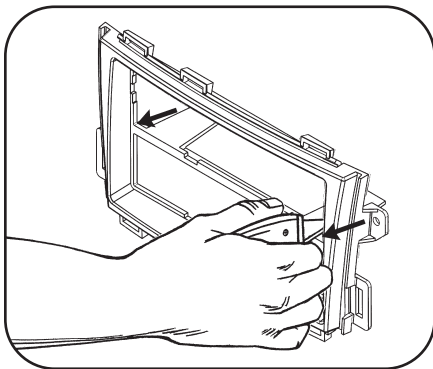

B

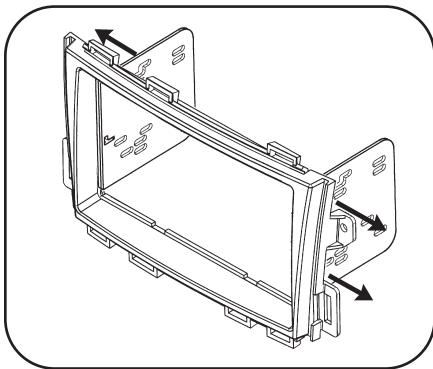

C

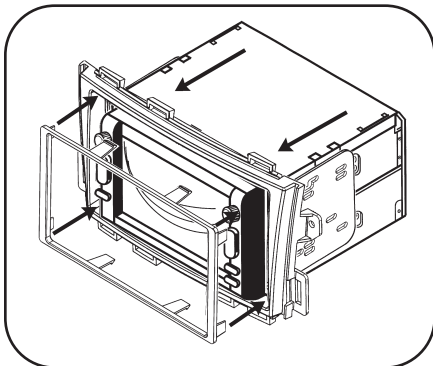



FINAL ASSEMBLY

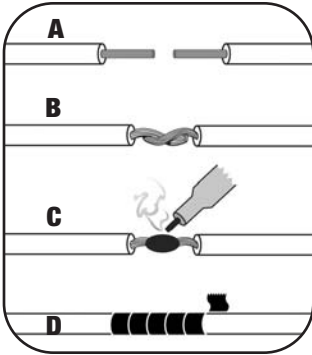

- (A) Strip wire ends back 1/2"**
- (B) Twist ends together**
- (C) Solder**
- (D) Tape**

- 1** Locate the factory wiring harness in the dash. Metra recommends using the proper mating adapter and making connections as shown. (Isolate and individually tape off the ends of any unused wires to prevent electrical short circuit.)
- 2** Re-connect the negative battery terminal and test the unit for proper operation.
- 3** Reassemble radio and dash assemblies in reverse order of disassembly.

FINAL WIRING CONNECTIONS

Make wiring connections using the EIA color code chart shown below and the instructions included with the head unit. Metra recommends making connections as shown below; Strip, Splice, Solder, Tape. Isolate and individually tape off ends of any unused wires to prevent electrical short circuit.

METRA / EIA WIRING CODE

12V Ignition / Acc. Red	Right Front (+) Gray
12V Batt / Memory. Yellow	Right Front (-). Gray/ Black
Ground. Black*	Left Front (+) White
Power Antenna. Blue	Left Front (-). White / Black
Amp Turn-On Blue / White	Right Rear (+) Violet
Amp Ground. Black / White	Right Rear (-) Violet / Black
Illumination Orange	Left Rear (+) Green
Dimmer Orange / White	Left Rear (-) Green / Black

***NOTE:** When a Black wire is not present, ground radio to vehicle chassis.
All colors may not be present on all leads due to manufacturer's specifications.



1-800-221-0932



www.metraonline.com