



INSTALLATION INSTRUCTIONS FOR PART 99-7514B

APPLICATIONS 2010 MAZDA 3

99-7514B

KIT FEATURES

- DIN Radio Provision with Pocket
- ISO Mount Radio Provision with Pocket
- Double DIN Radio Provision
- Stacked ISO Mount Units Provision
- **Painted A Matte Black Finish**



KIT COMPONENTS

- A) Radio Housing • B) ISO Brackets • C) ISO Trim Plate • D) Double DIN Brackets
- E) Double DIN Trim Plate • F) Pocket • G) (2) Radio Housing Brackets
- H) (2) #8X3/8" Phillips Screws • I) (4) Panel Clips

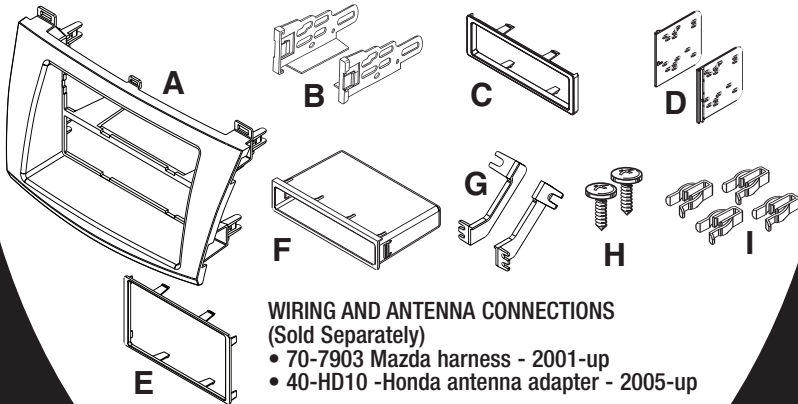

TOOLS REQUIRED:

- Small Flat Blade Screwdriver/ Panel Removal Tool
- Phillips Screwdriver



1-800-221-0932



www.metraonline.com

© COPYRIGHT 2009 METRA ELECTRONICS CORPORATION



TABLE OF CONTENTS

Dash Disassembly

- 2010 Mazda 31

Kit Preparation2

Kit Assembly

- DIN Mount Radio Provision with Pocket3

- ISO Mount Radio Provision with Pocket 4

- Double DIN /Stacked ISO Mount Units Radio Provision5

Note:

Refer also to the instructions included with the aftermarket radio.



KNOWLEDGE IS POWER

Enhance your installation and fabrication skills by enrolling in the most recognized and respected mobile electronics school in our industry. Log onto www.installerinstitute.com or call 800-354-6782 for more information and take steps toward a better tomorrow.

2010 MAZDA 3

- 1** Disconnect the negative battery terminal to prevent an accidental short circuit.
- 2** Unclip and remove the vent panel above the radio. (Figure A)
- 3** Remove (2) screws securing the factory radio. (Figure B)
- 4** Unclip and remove the factory radio. (Figure C)

Continued to kit assembly.

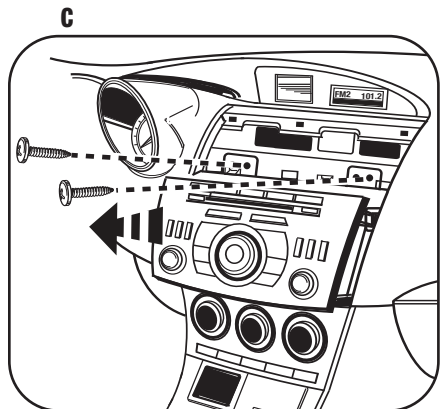
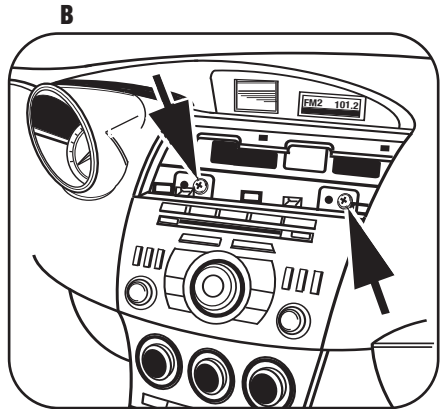
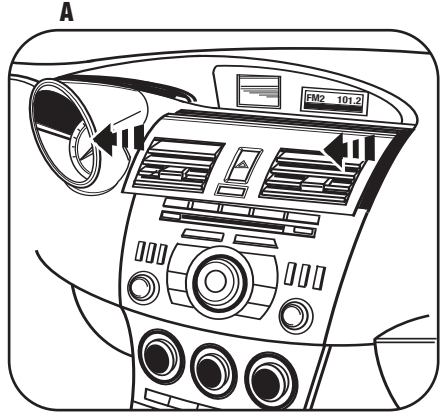



95-7514B KIT PREPARATION

2010 MAZDA 3

- 1 Attach the radio housing brackets to the radio housing using the provided (2) Phillips screws. (Figure A,B)
- 2 Attach the panel clips to the rear of the radio housing.

Continue to kit assembly.

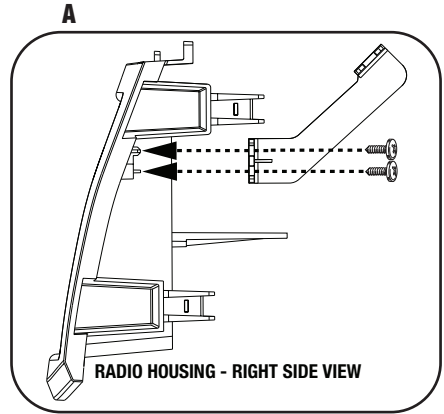

BEFORE BRACKET ASSEMBLY

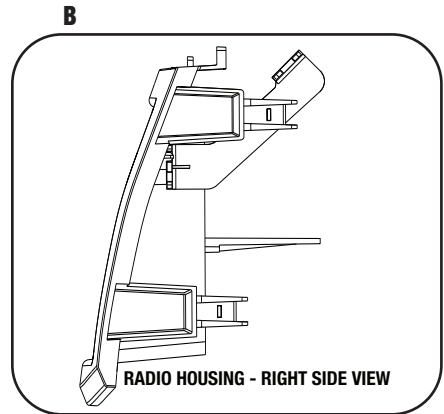

AFTER BRACKET ASSEMBLY

DIN MOUNT RADIO PROVISION WITH POCKET

**Note: Refer also to the instructions included with the aftermarket radio.*

- 1 Locate the factory wiring harness in the dash. Metra recommends using the proper mating adapter from Metra or AXXESS. Re-connect the negative battery terminal and test the unit for proper operation.
- 2 Slide the DIN cage into the Radio Housing and secure by bending the metal locking tabs down. (Figure A)
- 3 Snap the pocket into the bottom opening of the radio housing. (Figure B)
- 4 Slide the aftermarket head unit into the cage and secure. (Figure C)
- 5 Reassemble dash in reverse order of disassembly.

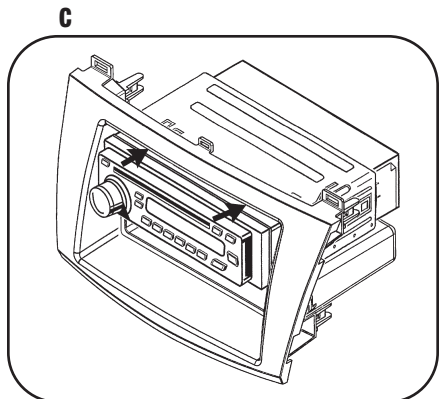
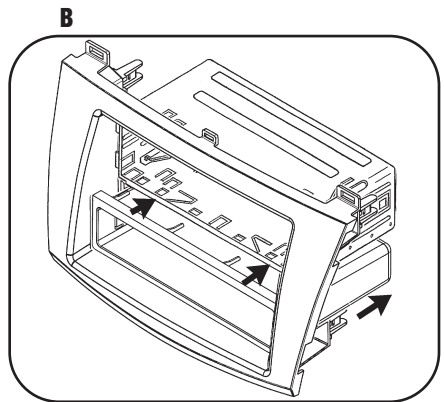
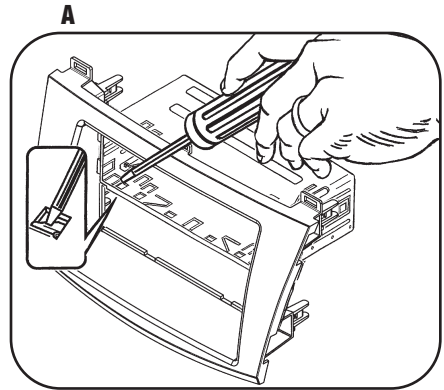

ISO MOUNT RADIO PROVISION WITH POCKET

**Note: Refer also to the instructions included with the aftermarket radio.*

- 1 Locate the factory wiring harness in the dash. Metra recommends using the proper mating adapter from Metra or AXCESS. Re-connect the negative battery terminal and test the unit for proper operation.
- 2 Mount the ISO Brackets to the head unit with the screws supplied with the unit. (Figure A)
- 3 Snap the pocket into the bottom opening of the radio housing. (Figure B)
- 4 Slide the head unit into the radio opening until the side clips engage. (Figure C)
- 5 Snap the Trim plate into the Radio Housing. (Figure C)
- 6 Reassemble dash in reverse order of disassembly.

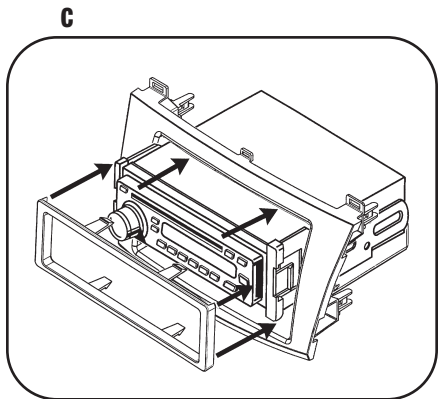
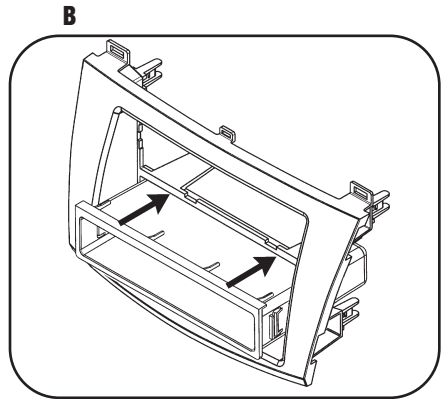
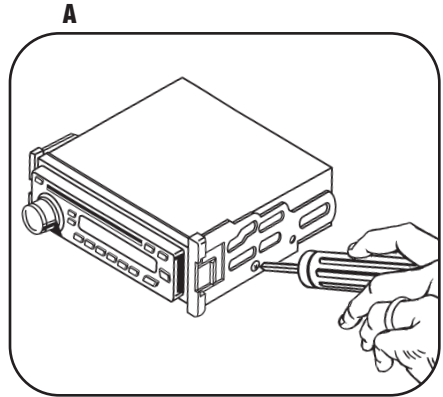

DOUBLE DIN/STACKED ISO MOUNT UNITS RADIO PROVISION

**Note: Refer also to the instructions included with the aftermarket radio.*

1 Locate the factory wiring harness in the dash. Metra recommends using the proper mating adapter from Metra or AXCESS. Re-connect the negative battery terminal and test the unit for proper operation.

2 Cut and remove the center bar from the radio housing. (Figure A)

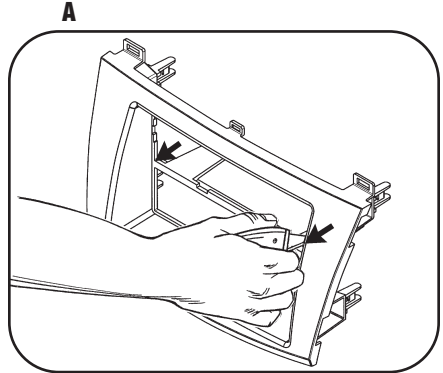

3 Snap the Double DIN brackets to the inside edge of the Double DIN trim plate. (Figure B)

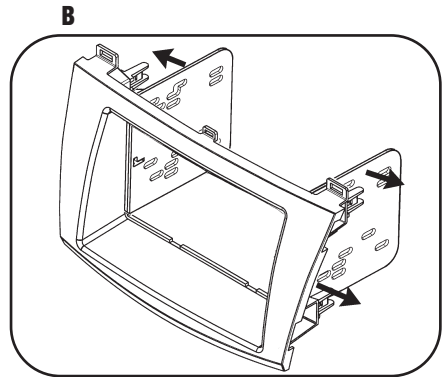

4 Slide the Double DIN head unit or stacked ISO head units into the bracket/radio housing assembly and secure the Double DIN head unit or stacked ISO head units to the assembly using the screws supplied with the radio. (Figure C)

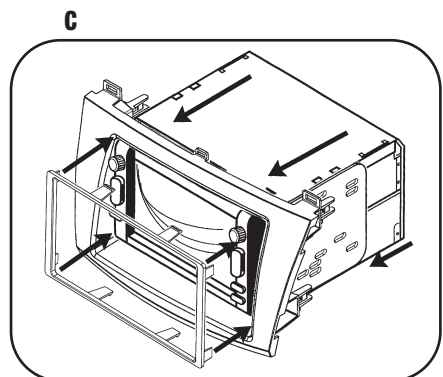

5 Snap the Double DIN trim plate into the Radio Housing. (Figure C)

6 Reassemble dash in reverse order of disassembly.

99-7514B INSTRUCTIONS



1-800-221-0932



www.metraonline.com

REV. 07/30/09 © COPYRIGHT 2009 METRA ELECTRONICS CORPORATION INST99-7514B