



INSTALLATION INSTRUCTIONS FOR PART 99-7607B

APPLICATIONS

NISSAN 370Z 2009

(Not for models equipped with factory NAV)

99-7607B

KIT FEATURES

- DIN Radio Provision
- ISO Mount Radio Provision
- Double DIN Radio Provision
- Stacked ISO Mount Units Provision
- **Painted matte black to match factory finish**



KIT COMPONENTS

- A) Radio Housing • B) ISO Brackets • C) ISO Trim Plate • D) Pocket • E) Double DIN Brackets
• F) Double DIN Trim Plate • G) A/C Module Brackets

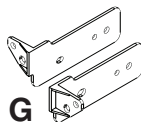
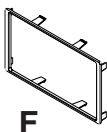
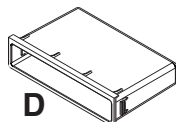
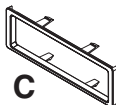
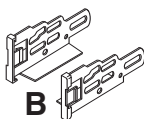
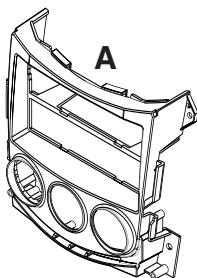

WIRING AND ANTENNA CONNECTIONS (Sold Separately)

Wiring Harness:

- 70-7552 - Nissan harness 2007-up
- 40-N112 - Nissan antenna adapter 2007-up

TOOLS REQUIRED:

- Panel Removal Tool
- Small Flat Blade Screwdriver
- Phillips Screwdriver
- Socket Set



1-800-221-0932



www.metraonline.com

© COPYRIGHT 2009 METRA ELECTRONICS CORPORATION



TABLE OF CONTENTS

Dash Disassembly

- NISSAN 370Z 2009 1,2

Kit Preparation 3

Kit Assembly

- DIN Radio Provision with Pocket 4

- ISO Mount Radio Provision with Pocket 5

- Double DIN/Stacked ISO Radio Provision..... 6

***Note:**

- Refer also to the instructions included with the aftermarket radio.

- (Not for models equipped with factory NAV)



KNOWLEDGE IS POWER

Enhance your installation and fabrication skills by enrolling in the most recognized and respected mobile electronics school in our industry. Log onto www.installerinstitute.com or call 800-354-6782 for more information and take steps toward a better tomorrow.

NISSAN 370Z 2009

1 Disconnect the negative battery terminal to prevent an accidental short circuit.

2 AUTOMATIC SHIFT MODELS:

Unclip and remove the small shifter trim panel including the hazard switch. (Figure A)

Unclip and remove the large shifter trim panel. (Figure B)

NOTE:

MANUAL SHIFT MODELS:

The shift trim is one piece, unsnap carefully and set aside.

3 Remove (1) Phillips screws from each side panel on the center console at the bottom of the radio panel then unclip and remove the panels. (Figure C)

Continue on page 2 .

A

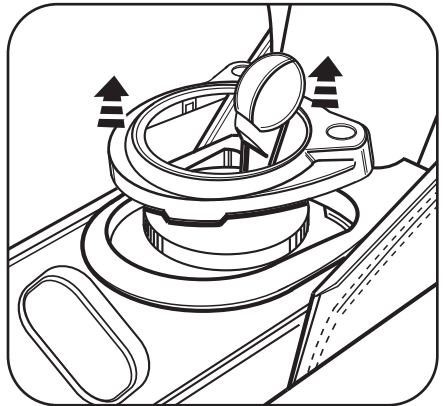

B

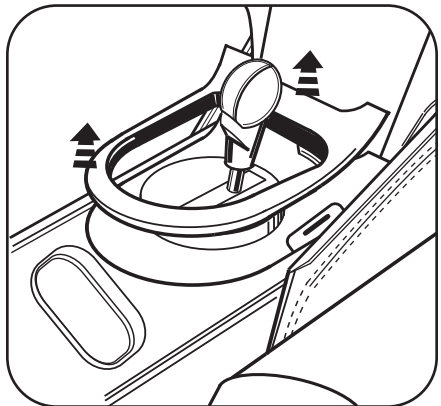

C

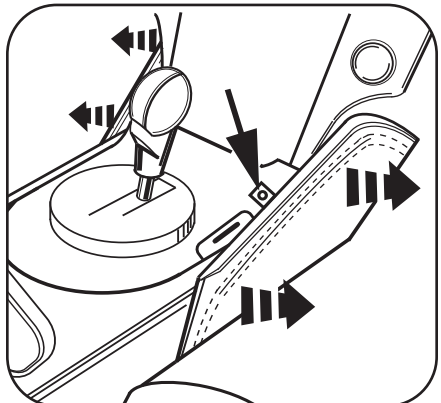

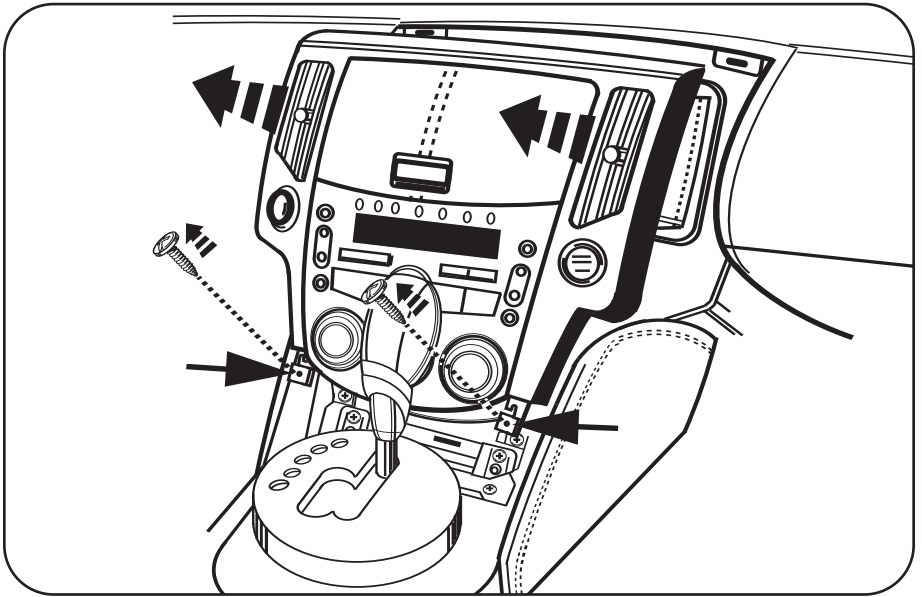
NISSAN 370Z 2009
D

4 Remove (2) Phillips screws from the bottom of the large trim panel including the a/c vents and pocket assembly then unclip and remove the panel. (Figure D)

5 Remove (4) Phillips screws securing the factory radio and a/c control. (Figure E)

6 Remove (5) Phillips screws securing the a/c control to the factory radio trim panel.

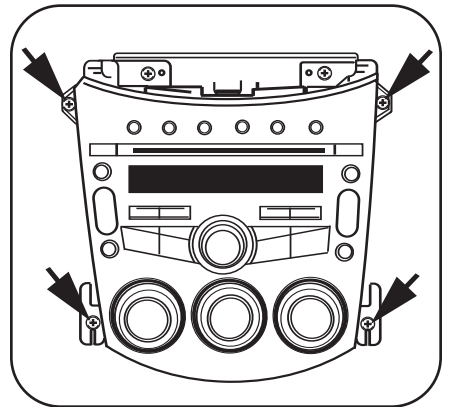
E

7 Remove (2) Phillips screws securing the a/c module to the factory radio bracket assembly.

Continue on kit assembly.

NISSAN 370Z 2009

- 1 Secure the a/c control into the 99-7607 radio housing using the factory hardware. (Figure A)

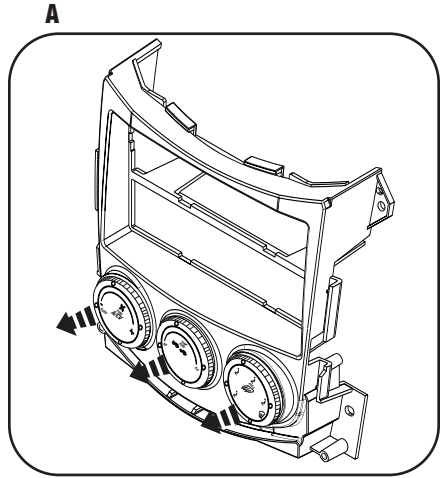

- 2 Attach the included brackets to the a/c module then secure it into the dash using the factory hardware. (Figure B)

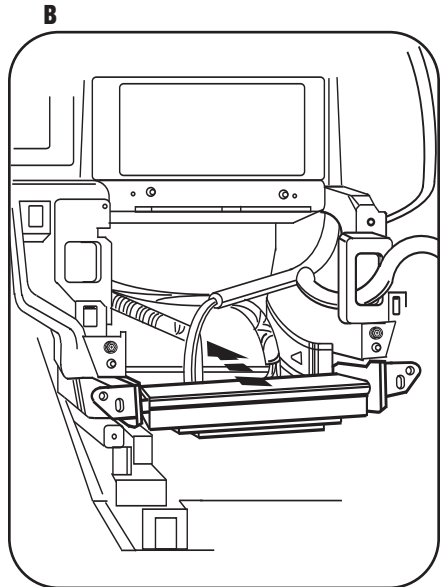

DIN RADIO PROVISION WITH POCKET

**Note: Refer also to the instructions included with the aftermarket radio.*

- 1 Locate the factory wiring harness in the dash. Metra recommends using the proper mating adapter from Metra or AXCESS. Re-connect the negative battery terminal and test the unit for proper operation.
- 2 Slide the DIN cage into the Radio Housing and secure by bending the metal locking tabs down. (Figure A)
- 3 Snap the pocket into the bottom opening of the radio housing. (Figure B)
- 4 Slide the aftermarket head unit into the cage and secure. (Figure C)
- 5 Reassemble dash in reverse order of disassembly.

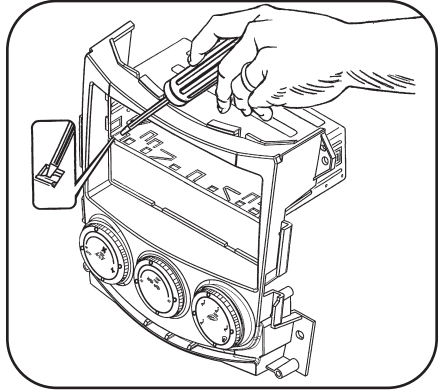
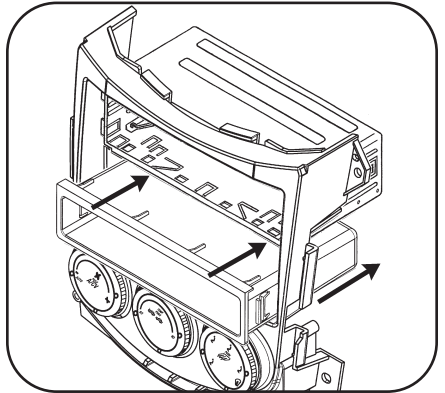
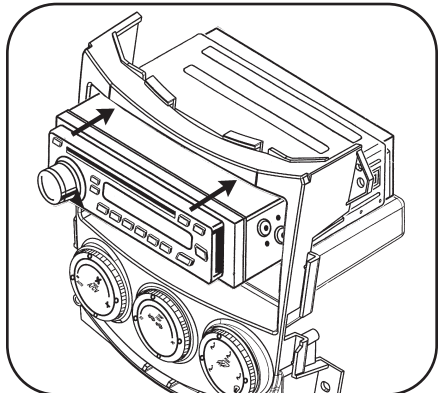
A**B****C**

ISO MOUNT RADIO PROVISION WITH POCKET

**Note: Refer also to the instructions included with the aftermarket radio.*

- 1** Locate the factory wiring harness in the dash. Metra recommends using the proper mating adapter from Metra or AXCESS. Re-connect the negative battery terminal and test the unit for proper operation.
- 2** Mount the ISO brackets to the head unit with the screws supplied with the radio. (Figure A)
- 3** Snap the pocket into the bottom opening of the radio housing. (Figure B)
- 4** Slide the head unit into the radio opening until the side clips engage. (Figure C)
- 5** Snap the Trim plate into the Radio Housing. (Figure C)
- 6** Reassemble dash in reverse order of disassembly.

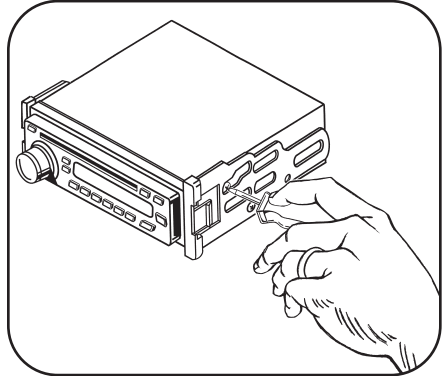
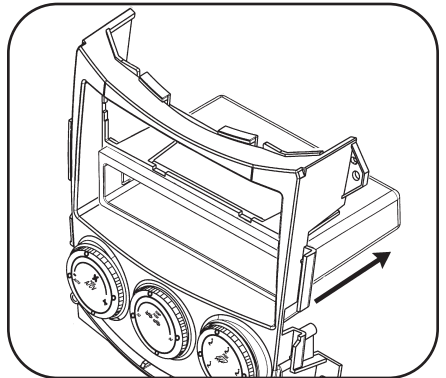
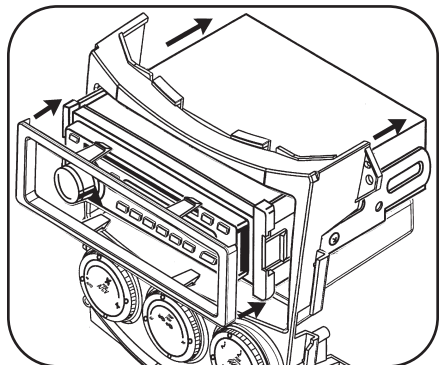
A

B

C



DOUBLE DIN/STACKED ISO UNITS RADIO PROVISION

**Note: Refer also to the instructions included with the aftermarket radio.*

- 1 Locate the factory wiring harness in the dash. Metra recommends using the proper mating adapter from Metra or AXCESS. Re-connect the negative battery terminal and test the unit for proper operation.
- 2 Cut and remove the center bar from the radio housing. (Figure A)
- 3 Snap the Double DIN brackets to the inside edge of the radio housing. (Figure B)
- 4 Slide the Double DIN radio into the bracket/trim plate assembly and secure the radio to the assembly using the screws supplied with the radio. (Figure C)
- 5 Snap the Double DIN trim-plate onto the housing/radio assembly. (Figure C)
- 6 Reassemble dash in reverse order of disassembly.

A

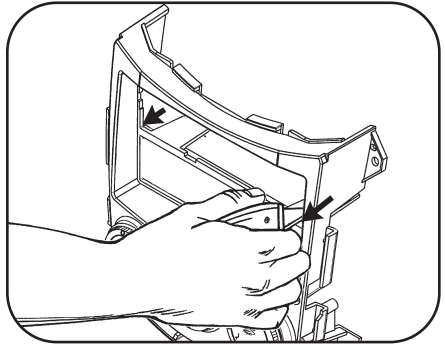

B

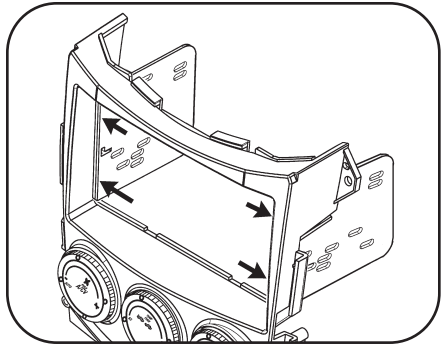

C

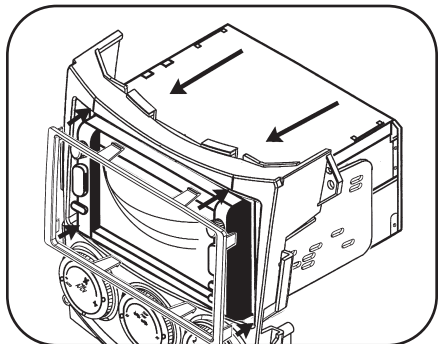

1-800-221-0932



www.metraonline.com