



## INSTALLATION INSTRUCTIONS FOR PART 99-7805CH

### APPLICATIONS

# Acura TSX 2009-up 99-7805CH



### KIT FEATURES

- ISO DIN radio provision with pocket
- *Painted charcoal gray*

### KIT COMPONENTS

- A) Radio Housing • B) Radio Housing Brackets • C) Pocket • D) (4) #8 x 3/8" Truss-head Phillips screws
- E) (2) #8 x 1/2" Truss-head Phillips screws • F) (4) #8 x 3/8" Pan-head Phillips screws

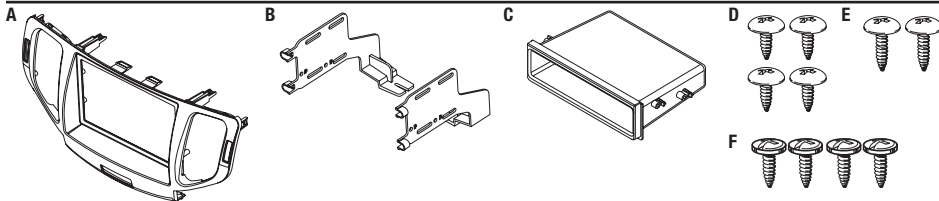

### WIRING & ANTENNA CONNECTIONS (sold separately)

Wiring Harness: • 70-1729 Honda harness 2008-up • 70-1730 Honda amp interface harness 2008-up

Antenna Adapter: • 40-HD10 Acura/Honda antenna adapter 2005-up into car  
• 40-HD12 Acura/Honda antenna adapter 2005-up into car

## Table of Contents

### Dash Disassembly

– Acura TSX 2009-up.....2-5

### Kit Assembly

– ISO DIN radio provision with pocket..... 6

### TOOLS REQUIRED

- Panel removal tool • Phillips screwdriver
- Socket wrench

**CAUTION:** *Metra recommends disconnecting the negative battery terminal before beginning any installation. All accessories, switches, and especially air bag indicator lights must be plugged in before reconnecting the battery or cycling the ignition.*

**NOTE:** *Refer to the instructions included with the aftermarket radio.*

## Dash Disassembly

1. Unclip and remove the trim panel above the glove box on the passenger side of the dash. (Figure A)
2. Unclip and remove the driver and passenger side trim panels from the console. (Figure B and C)

*Continued on next page*

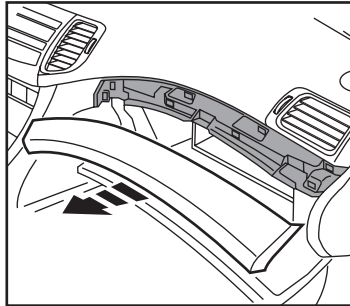

(Figure A)

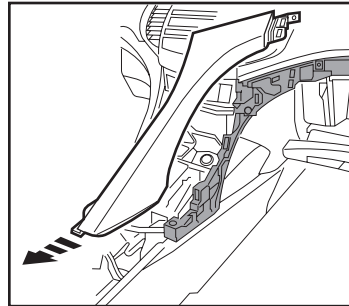

(Figure B)

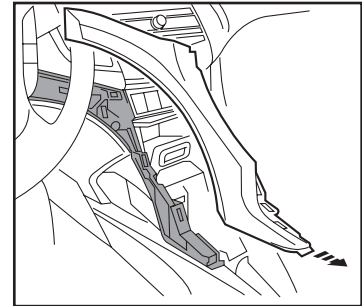

(Figure C)

## Dash Disassembly

3. Unclip and remove the shifter panel including the cup holders. (Figure D)
4. Unclip and remove the coin holder from the 12 volt socket/coin holder assembly. (Figure E)

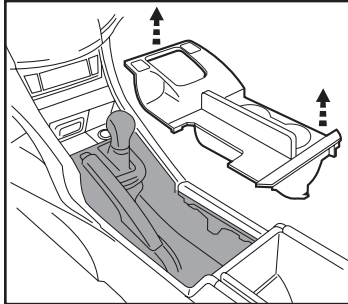

(Figure D)

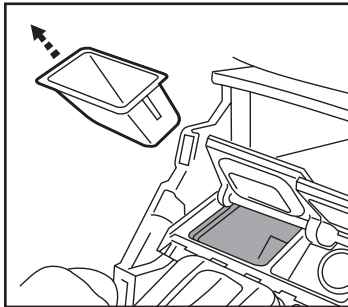

(Figure E)

5. Remove (1) Phillips screw under coin holder then unclip and remove 12 volt socket/coin holder assembly. (Figure F)
6. Remove (4) Phillips screws securing the pocket assembly then unclip and remove the pocket. (Figure G)

*Continued on next page*

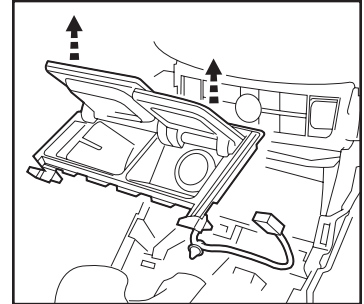

(Figure F)

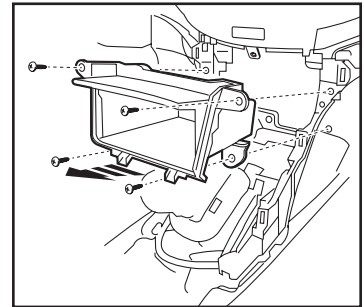

(Figure G)

## Dash Disassembly

7. Remove (4) Phillips screws securing the climate control then unplug and remove the control. (Figure H)
8. Remove (2) Phillips screws facing up under factory radio. (Figure I)
9. Remove (2) Phillips screws securing the hazard switch.
10. Remove the (4) plastic clips from the factory radio assembly.

*Continued on next page*

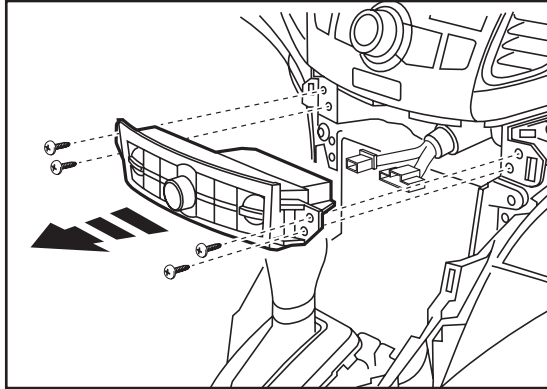

(Figure H)

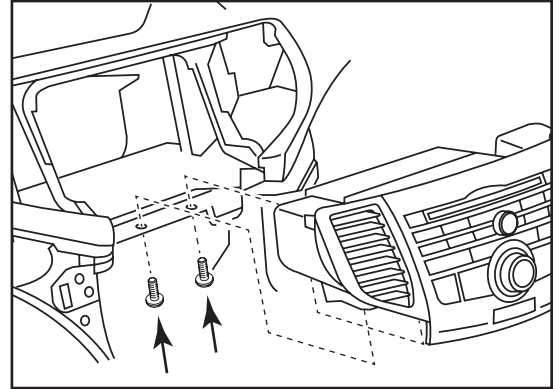

(Figure I)

## Dash Disassembly

11. Remove (2) Phillips screws per vent securing the a/c vents to the radio panel then unclip and remove the vents. (Figure J)

*Continue to kit assembly*

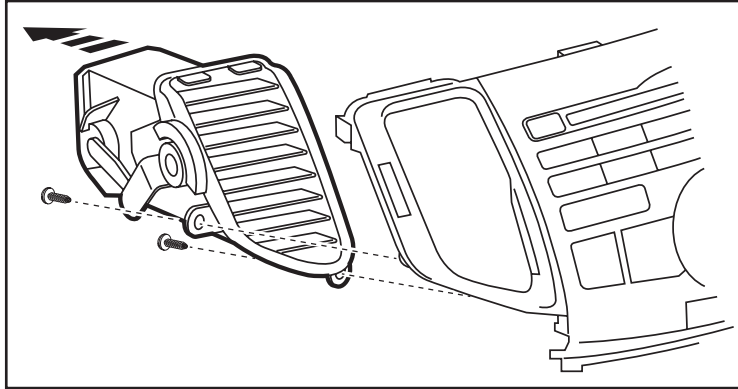

(Figure J)

## Kit Assembly

### ISO DIN radio provision

1. Attach the (4) panel clips to the radio housing. (Figure A)
2. Mount the pocket to the radio brackets with the (4) #8 x 3/8" Truss-head Phillips screws supplied. (Figure B)
3. Mount the bracket/pocket assembly to the radio housing with the included (4) #8 x 3/8" Pan-head Phillips screws. (Figure C)

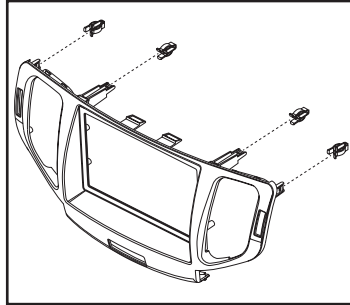

(Figure A)

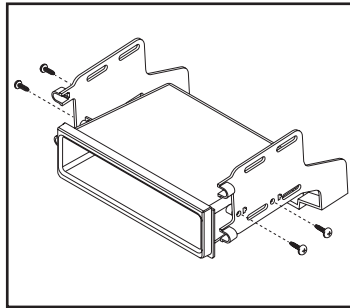

(Figure B)

4. Slide the radio into radio brackets and secure with screws supplied with the radio. (Figure D)
5. Attach the A/C vents to the radio housing using the factory hardware.
6. Attach the hazard switch to the radio housing using the supplied (2) #8 x 1/2" Truss-head Phillips screws.
7. Locate the factory wiring harness and antenna plug in the dash. Metra recommends using the proper mating adapters from Metra and/or AXCESS.
8. Reassemble dash in reverse order of disassembly.

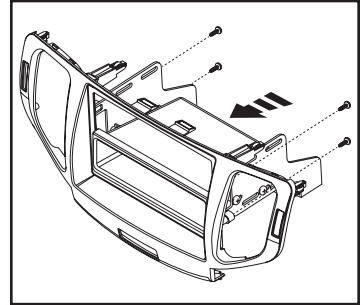

(Figure C)

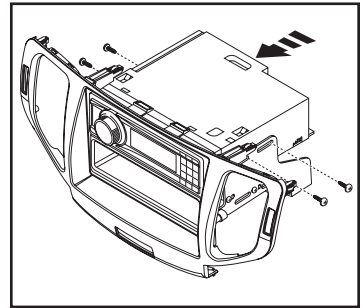

(Figure D)





## INSTALLATION INSTRUCTIONS FOR PART 99-7805CH



REV. 1/6/2014 INST99-7805CH



### KNOWLEDGE IS POWER

Enhance your installation and fabrication skills by enrolling in the most recognized and respected mobile electronics school in our industry. Log onto [www.installerinstitute.com](http://www.installerinstitute.com) or call 800-354-6782 for more information and take steps toward a better tomorrow.



**Metra recommends MECP certified technicians**