



## INSTALLATION INSTRUCTIONS FOR PART 99-7863

### APPLICATIONS

# Honda Element 2003-2006

# 99-7863



### KIT FEATURES

- DIN Head Unit Provision with pocket
- ISO Head Unit Provision with pocket

### KIT COMPONENTS

- A) Radio Housing • B) ISO Trimplate • C) ISO Snap in Brackets

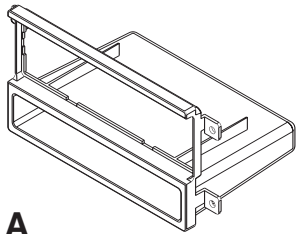

A

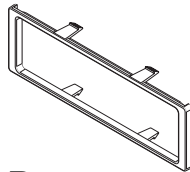

B

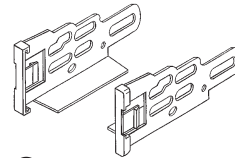

C

### TOOLS REQUIRED:

Phillips Screwdriver

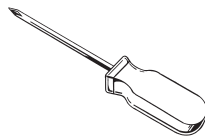

1-800-221-0932



[www.metraonline.com](http://www.metraonline.com)

© COPYRIGHT 2004 METRA ELECTRONICS CORPORATION



# **TABLE OF CONTENTS**

## **Dash Disassembly**

**- Honda Element 2003-2006 ..... 1**

## **Kit Assembly**

**- DIN Head Unit Provision with Pocket ..... 2**

**- ISO Head Unit Provision with Pocket ..... 3**

**Final Assembly ..... 4**

**HONDA ELEMENT 2003-2006**

- 1 Disconnect the negative battery terminal to prevent an accidental short circuit.
- 2 Unsnap and remove shift lever trim panel. For manual transmission models, untwist shift knob. (Figure A)

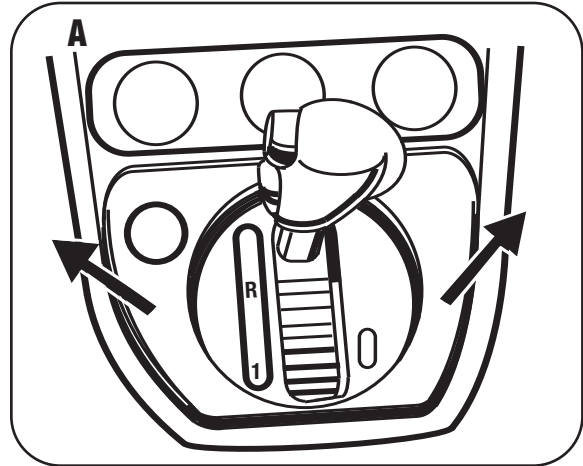

- 3 Unsnap and remove center dash panel. (Figure B)

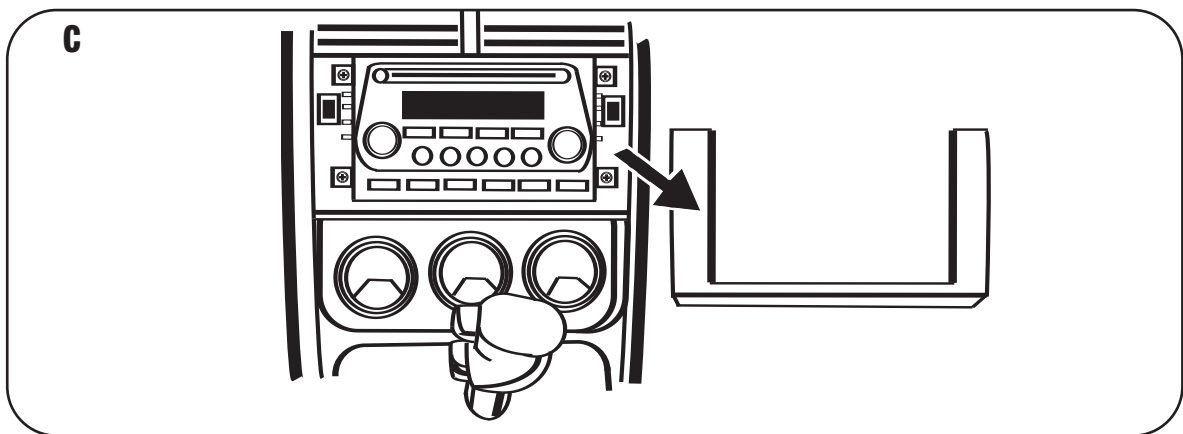
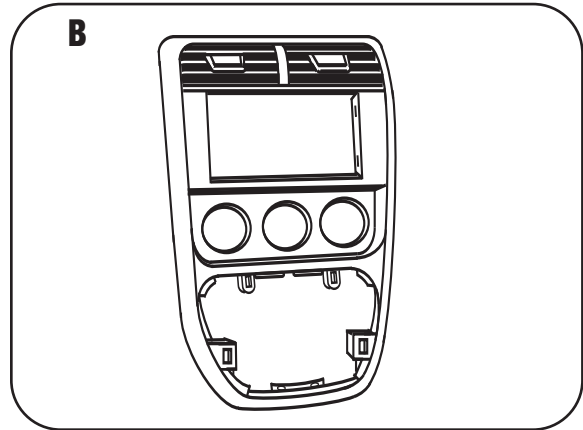

**NOTE:** As an option, the center panel (the smaller piece around radio) is all that needs to be removed, but it is very prone to damage, so full panel removal is recommended. (Figure C)

- 4 Remove (4) Phillips screws and remove radio. Continue to kit assembly. (Figure C)

## DIN HEAD UNIT PROVISION WITH POCKET

- 1** Slide the DIN cage into the Radio Housing and secure by bending the metal locking tabs down. (Figure A)
- 2** Slide the aftermarket radio into the cage and secure. (Figure B)

Continue to final assembly.

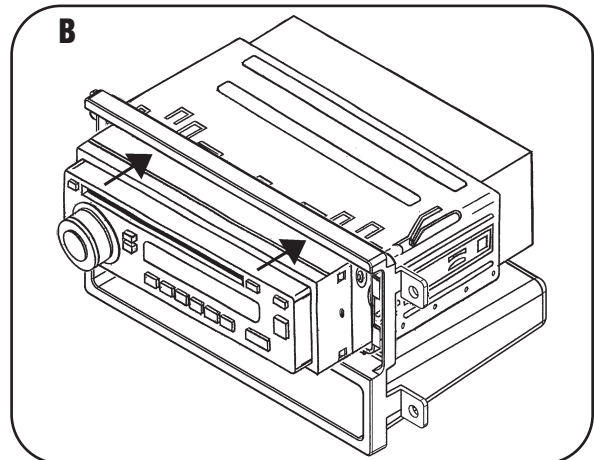
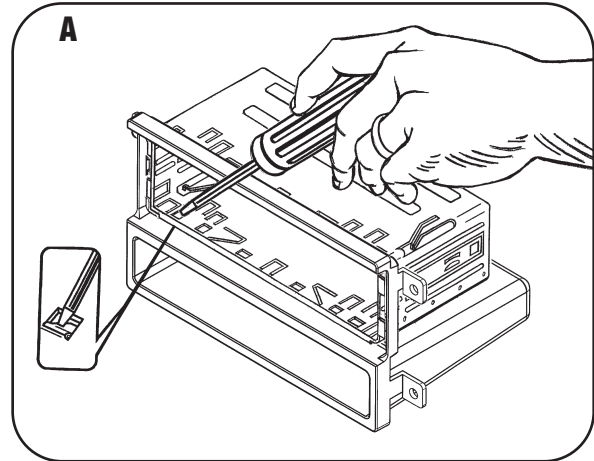

## ISO HEAD UNIT PROVISION WITH POCKET

- 1** Align the holes in the ISO snap In brackets with the holes in the head unit and mount the brackets to the head unit with the screws supplied with the unit. (Figure A)
- 2** Slide the aftermarket head unit/bracket assembly into the radio opening until the side clips engage. (Figure B)
- 3** Snap the ISO trimplate over the head unit. (Figure B)

Continue to final assembly.

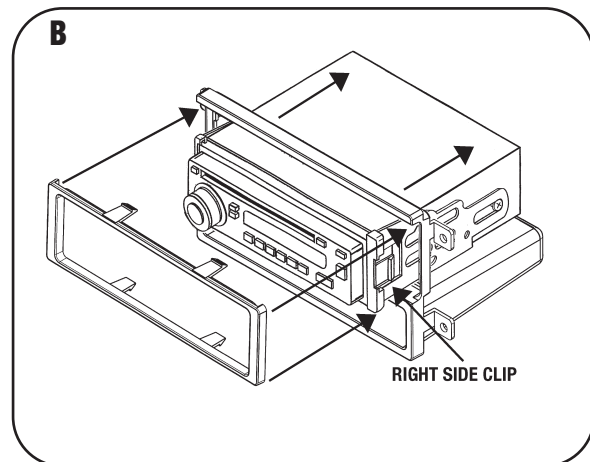
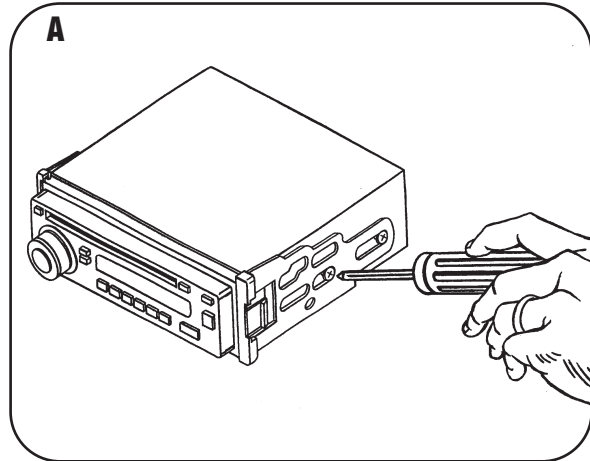

# FINAL ASSEMBLY

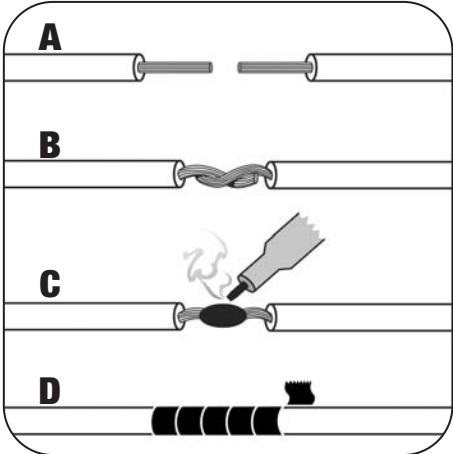

- A) Strip wire ends back 1/2"**
- B) Twist ends together**
- C) Solder**
- D) Tape**

- 1** Locate the factory wiring harness in the dash. Metra recommends using the proper mating adapter and making connections as shown. (Isolate and individually tape off the ends of any unused wires to prevent electrical short circuit.)
- 2** Re-connect the negative battery terminal and test the unit for proper operation.
- 3** Reassemble in reverse order of disassembly.

## FINAL WIRING CONNECTIONS

Make wiring connections using the EIA color code chart shown below and the instructions included with the head unit. Metra recommends making connections as shown below; Strip, Splice, Solder, Tape. Isolate and individually tape off ends of any unused wires to prevent electrical short circuit.

### METRA / EIA WIRING CODE

12V Ignition / Acc . . . Red	Right Front (+) . . . . Gray
12V Batt / Memory . . Yellow	Right Front (-) . . . . Gray/ Black
Ground . . . . . Black*	Left Front (+) . . . . . White
Power Antenna . . . . . Blue	Left Front (-) . . . . . White / Black
Amp Turn-On . . . . . Blue / White	Right Rear (+) . . . . . Violet
Amp Ground . . . . . Black / White	Right Rear (-) . . . . . Violet / Black
Illumination . . . . . Orange	Left Rear (+) . . . . . Green
Dimmer . . . . . Orange / White	Left Rear (-) . . . . . Green / Black

**\*NOTE:** When a Black wire is not present, ground radio to vehicle chassis.  
 All colors may not be present on all leads due to manufacturer's specifications.



# 99-7863 INSTRUCTIONS



**1-800-221-0932**



**[www.metraonline.com](http://www.metraonline.com)**

REV. 05/08/06

© COPYRIGHT 2004 METRA ELECTRONICS CORPORATION

INST99-7863