



INSTALLATION INSTRUCTIONS FOR PART 99-8232B

APPLICATIONS

Toyota Camry 2012-up 99-8232B

KIT FEATURES

- ISO DIN head unit provision with pocket
- DDIN head unit provisions
- *Painted Matte Black*

KIT COMPONENTS

- A) Radio Trim Panel • B) Pocket • C) Panel Clips • D) (4) #8 x 3/8" Phillips screws

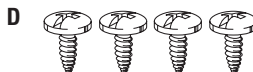
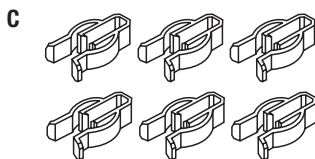
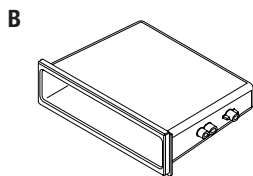
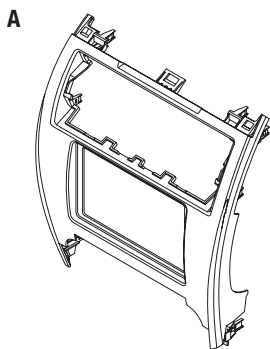

WIRING & ANTENNA CONNECTIONS (Sold Separately)

Wiring Harness: • 70-1761 - Toyota harness 1987-up

- TYTO-01 Toyota amp interface harness 2003-up

Antenna Adapter: • 44-LX11 Toyota/Lexus antenna adapter 2002-up

TOOLS REQUIRED

Panel Removal Tool • Phillips Screwdriver • Socket Wrench

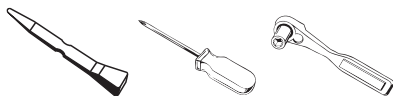

METRA. THE WORLD'S BEST KITS.™



1-800-221-0932



metraonline.com

© COPYRIGHT 2004-2011 METRA ELECTRONICS CORPORATION



99-8232B

Table of Contents

Dash Disassembly

– Toyota Camry 2012-up.....3-5

Kit Assembly

– ISO DIN head unit provision with pocket.....6

– DDIN head unit provisions.....7

Caution

Metra recommends disconnecting the negative battery terminal before beginning any installation. All accessories, switches, and especially air bag indicator lights must be plugged in before reconnecting the battery or cycling the ignition.

**NOTE: Refer also to the instructions included with the aftermarket radio.*



KNOWLEDGE IS POWER

Enhance your installation and fabrication skills by enrolling in the most recognized and respected mobile electronics school in our industry. Log onto www.installerinstitute.com or call 800-354-6782 for more information and take steps toward a better tomorrow.



Metra recommends MECP certified technicians

Toyota Camry 2012-up

1. Unclip and remove the A/C vent register. (Figure A)
2. Unclip and remove the panel above the radio including the clock. (Figure B)

Note: Be very careful with center clip on panel it is very fragile.

3. Unclip and remove (1) trim panel from each side of the pocket below the radio/ climate control assembly. (2 panels total) (Figure C)

Continued on next page

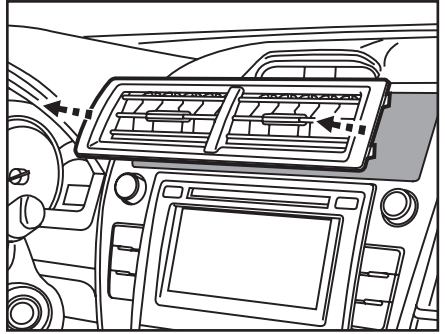

(Figure A)

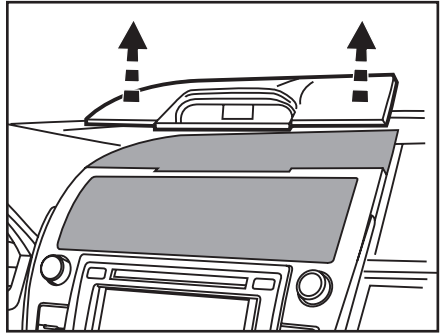

(Figure B)

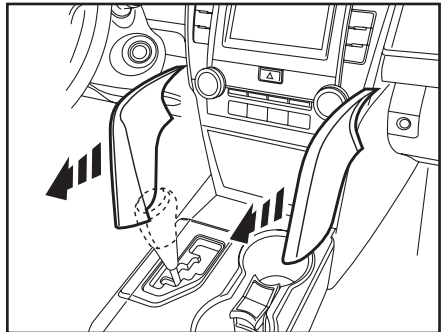

(Figure C)

Toyota Camry 2012-up

4. Turn the shift knob counter clockwise to remove. (Figure D)
5. Unclip and remove the top of the center console including the cup holders. (Figure E)
6. Remove (2) Phillips screws from the front of the center console and (2) 12mm bolts from inside of the arm rest storage box. (Figure F)
7. Slide the center console toward the rear of the vehicle to make clearance for the pocket removal. (Figure F)

Continued on next page

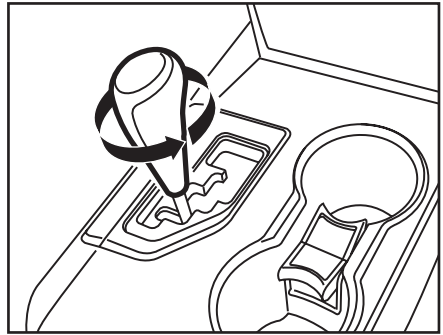

(Figure D)

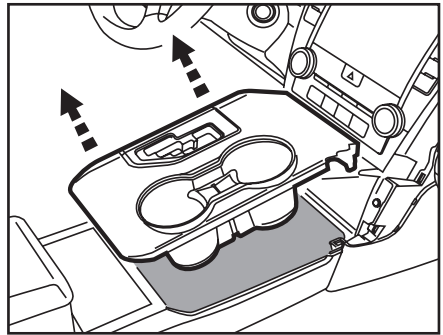

(Figure E)

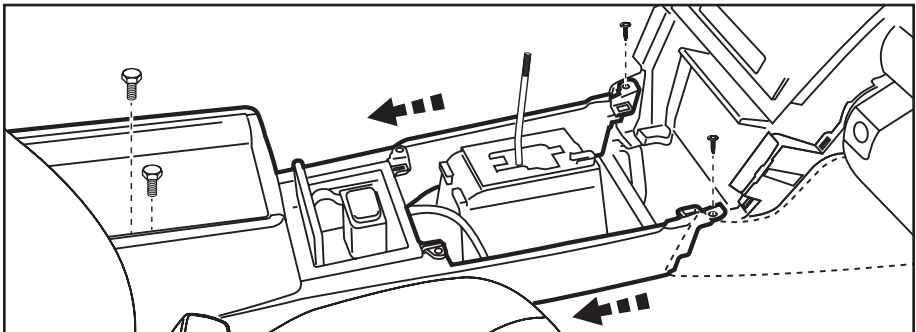

(Figure F)

Toyota Camry 2012-up

8. Remove (1) Phillips screw from each side of the pocket below the radio/ climate control assembly. (2 screws total) (Figure G)

9. Unclip and remove the pocket. (Figure G)

10. Remove (2) 10 mm bolts above the radio (behind the a/c vents) and (2) 10 mm bolts from behind the climate control then unplug and remove the assembly. (Figure H)

11. Remove (10) Phillips screws securing the brackets to the radio/climate control assembly and separate the radio from the climate controls. (Retain the factory panel clips, climate controls, brackets and screws for use during kit assembly).

Continue to kit assembly

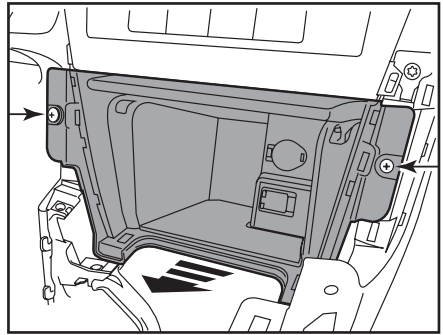

(Figure G)

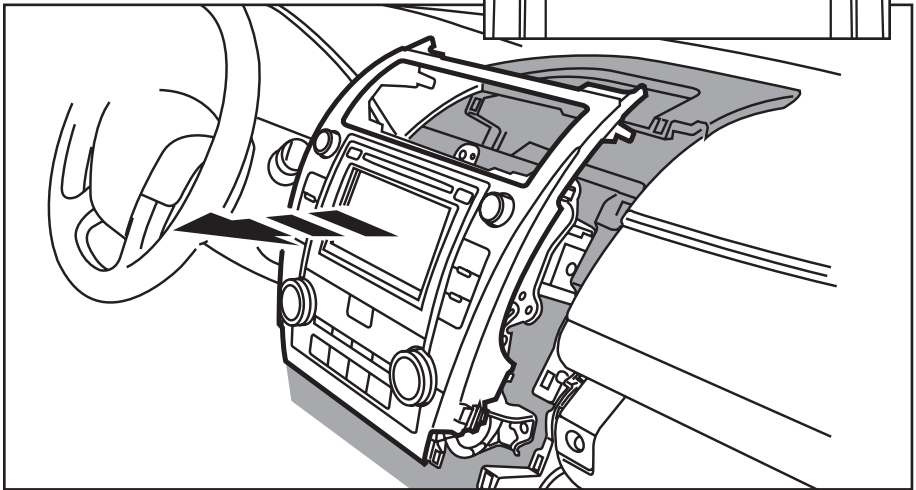
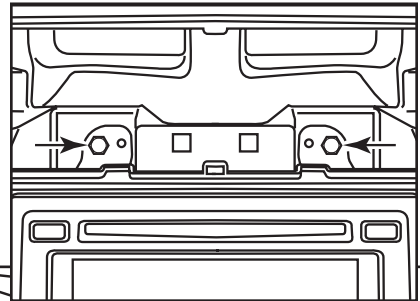

(Figure H)



Kit Assembly 99-8232B

ISO DIN head unit provisions with pocket

1. Remove the factory panel clips and attach to the Metra radio trim panel in the same order. This kit comes with six panel clips that will only work with the upper six locations around the vents. The two lower clips must be factory.
2. Mount the climate control to the factory brackets with the factory hardware. (Figure A)
3. Mount the pocket to the climate control/bracket assembly with the (4) #8 x 3/8" Phillips screws supplied. (Figure A)
4. Slide the head unit into the bracket assembly and secure with screws supplied with the unit. (Figure A)
5. Locate the factory wiring harness in the dash. Metra recommends using the proper mating adapter from Metra or AXCESS. Re-connect the negative battery terminal and test the unit for proper operation.
6. Mount the radio/pocket/climate control assembly into the dash.
7. Reassemble dash in reverse order of disassembly using the 99-8232B radio trim panel.

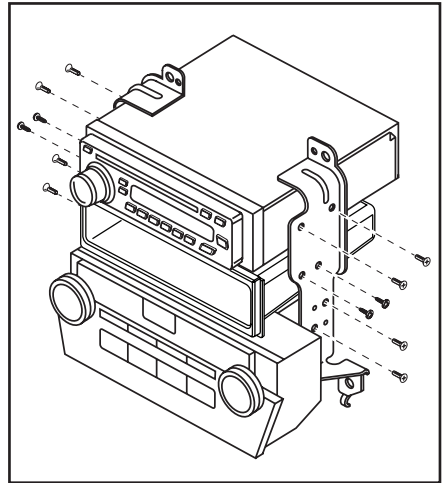

(Figure A)



Kit Assembly 99-8232B

Double DIN head unit provisions

1. Remove the factory panel clips and attach to the Metra radio trim panel in the same order. This kit comes with six panel clips that will only work with the upper six locations around the vents. The two lower clips must be factory.
2. Mount the climate control to the factory brackets with the factory hardware. (Figure A)
3. Mount the DDIN head unit to the climate control/brackets assembly using the screws supplied with the head unit. (Figure A)
4. Locate the factory wiring harness in the dash. Metra recommends using the proper mating adapter from Metra or AXCESS. Re-connect the negative battery terminal and test the unit for proper operation.
5. Mount the radio/climate control assembly into the dash.
6. Reassemble dash in reverse order of disassembly using the 99-8232B radio trim panel.

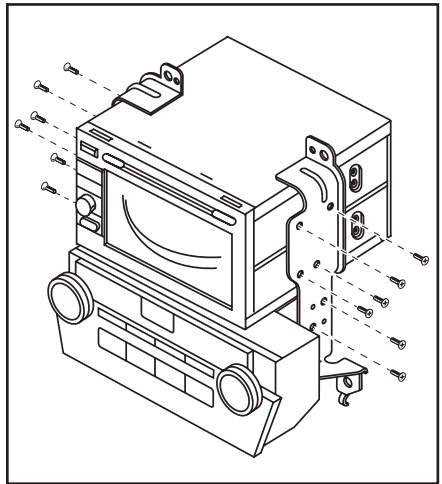

(Figure A)



INSTALLATION INSTRUCTIONS FOR PART 99-8232B

REV. 6/8/12 INST99-8232B



1-800-221-0932



metraonline.com

© COPYRIGHT 2004-2011 METRA ELECTRONICS CORPORATION