



Installation instructions for part 99-8250

## Toyota Sienna 2015-up 99-8250

### KIT FEATURES

- ISO DIN radio provision with pocket



### KIT COMPONENTS

- A) Radio trim panel • B) Radio brackets • C) Pocket • D) (8) #8 x 3/8" Phillips screws

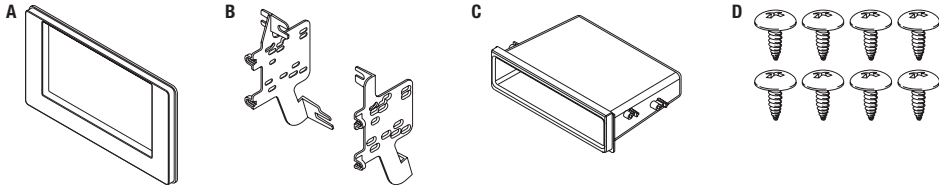

### WIRING & ANTENNA CONNECTIONS (sold separately)

Wiring Harness: • 70-1761 • TYTO-01

Antenna Adapter: • 40-LX11

### Table of Contents

Dash Disassembly .....	2
<b>Kit Assembly</b>	
– ISO DIN radio provision with pocket.....	3

### TOOLS REQUIRED

- Panel removal tool • Phillips screwdriver
- Socket wrench

**CAUTION:** Metra recommends disconnecting the negative battery terminal before beginning any installation, unless the vehicle manufacturer recommends against so. Please check with your local Dealership for more information. All accessories, switches, climate controls panels, and especially air bag indicator lights must be connected before reconnecting the battery or cycling the ignition. Also, do not remove the factory radio with the key in the on position, or the vehicle running. It would be best to remove the key from the ignition and then wait a few seconds before removing the factory radio.

REV. 6/26/2015 INST99-8250

## Dash Disassembly

1. Unscrew the shift lever knob.  
(Figure A)
2. Unsnap and remove the top dash trim panel (across instrument cluster and radio). (Figure B)

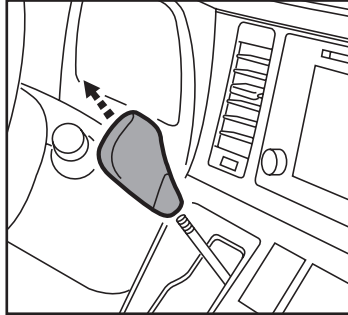

(Figure A)

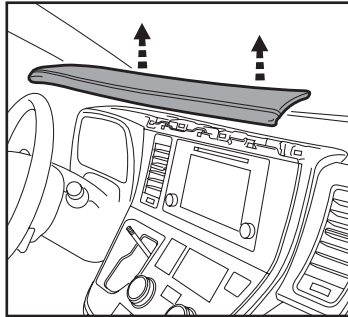

(Figure B)

3. Unsnap the instrument panel trim. Not necessary to completely remove. (Figure C)
4. Unsnap the radio trim panel including the climate controls. (Figure D)
5. Remove (4) 10 mm screws to remove the radio

*Continue to kit assembly*

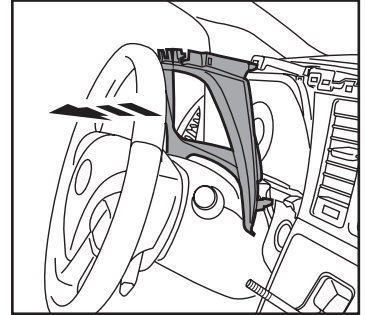

(Figure C)

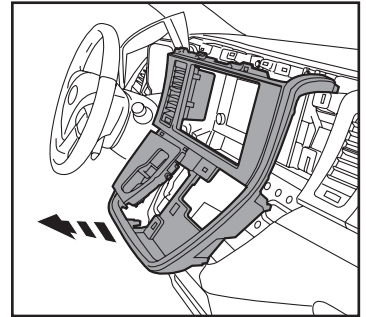

(Figure D)

## Kit Assembly

### ISO DIN radio provision with pocket

1. Attach the radio brackets to the radio trim panel using (4) #8 x 3/8" Phillips screws supplied. (Figure A)
2. Attach the pocket to the bracket assembly using the (4) #8 x 3/8" Phillips screws supplied. (Figure B)
3. Remove the metal DIN sleeve and trim ring from the aftermarket radio.
4. Slide the radio into the completed assembly, and then secure it to the assembly using screws supplied with the radio. (Figure C)
5. Locate the factory wiring harness and antenna connector in the dash, and complete all necessary connections to the radio. Metra recommends using the proper mating adapter from Metra and/or AXCESS. Re-connect the negative battery terminal and test the radio for proper operation.
6. Reassemble the dash in reverse order of disassembly.

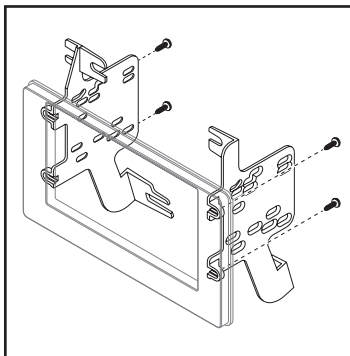

(Figure A)

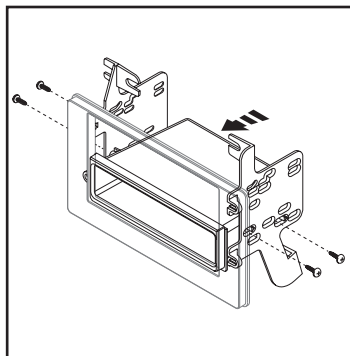

(Figure B)

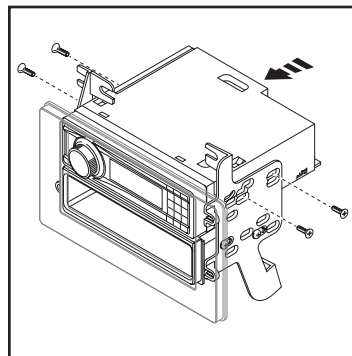

(Figure C)



Installation instructions for part 99-8250



**IMPORTANT**

*If you are having difficulties with the installation of this product, please call our Tech Support line at 1-800-253-TECH. Before doing so, look over the instructions a second time, and make sure the installation was performed exactly as the instructions are stated. Please have the vehicle apart and ready to perform troubleshooting steps before calling.*



**KNOWLEDGE IS POWER**

Enhance your installation and fabrication skills by enrolling in the most recognized and respected mobile electronics school in our industry. Log onto [www.installerinstitute.com](http://www.installerinstitute.com) or call 800-354-6782 for more information and take steps toward a better tomorrow.



**Metra recommends MECP certified technicians**

REV. 6/26/2015 INST99-8250