



INSTALLATION INSTRUCTIONS FOR PART 99-9304

APPLICATIONS

BMW

1 Series 2008 / 3 Series 2006-08
(Without Factory Navigation)

99-9304



KIT FEATURES

- DIN Head Unit Provision

KIT COMPONENTS

A) Radio Housing

TOOLS REQUIRED:

Small Flat Blade Screwdriver • Phillips Screwdriver

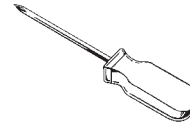
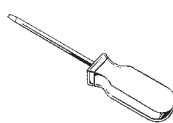

TABLE OF CONTENTS

Dash Disassembly: pg. 1

Kit Assembly: pg. 2

Final Assembly: pg. 3



1-800-221-0932



www.metraonline.com

© COPYRIGHT 2004-08 METRA ELECTRONICS CORPORATION



TABLE OF CONTENTS

<i>Dash Disassembly</i>	1
<i>Kit Assembly</i>	2
<i>Final Assembly</i>	3

DASH DISASSEMBLY

BMW 1 Series 2008 3 Series 2006-08

- 1 Disconnect the negative battery terminal to prevent an accidental short circuit.
- 2 Carefully unclip and remove climate controls. (Figure A)
- 3 Remove (2) Phillips screws exposed at bottom of radio and remove. (Figure B)

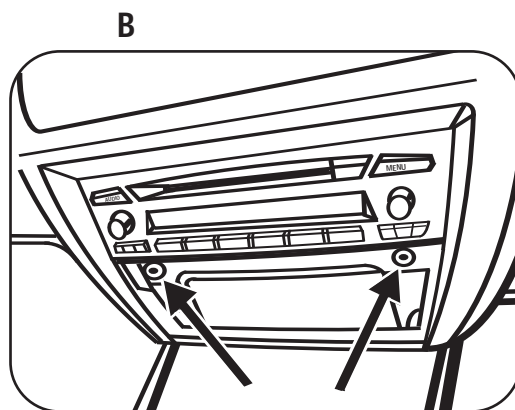
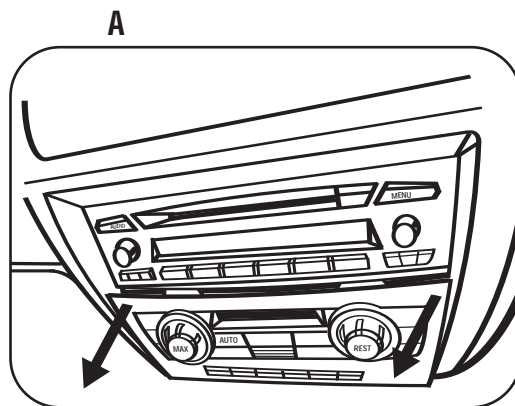

99-9304

DIN HEAD UNIT PROVISION

- 1 Screw the 99-9304 housing into the dash opening instead of the factory radio. (Figure A)
- 2 Slide the DIN cage into the space in the 99-9304 and secure by bending the metal locking tabs outward. (Figure B)
- 3 Slide the aftermarket head unit into the DIN cage until secure. (Figure C)

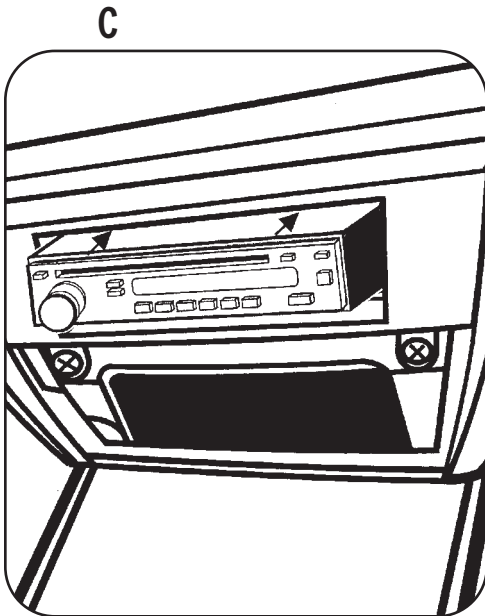
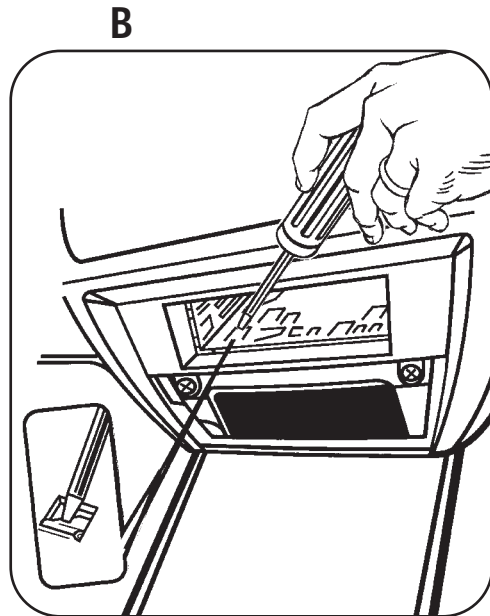

KIT ASSEMBLY



FINAL ASSEMBLY

- 1 At this time Metra does not offer a wiring harness or interface for this vehicle.
- 2 Re-connect the negative battery terminal and test the unit for proper operation.
- 3 Reassemble radio and dash assemblies in reverse order of disassembly.

INST99-9304



1-800-221-0932



www.metraonline.com

Rev. 06-11-08

© COPYRIGHT 2004-08 METRA ELECTRONICS CORPORATION

INST99-9304