

WIRELESS KEYPAD TYPE KEYLESS ENTRY

CODE LEARNING (FOR FOUR BUTTON TRANSMITTER) OPTIONAL ITEM

To replace lost or stolen transmitters. Please have all desired transmitters ready and follow the steps below.

1. Put the DIP SWITCH 1 to ON (UP) position. The parking light will flash TWICE to indicate the module is in code learning mode.
2. Press and release any button on the transmitter. The parking will flash FOUR times to confirm the NEW code has been learned.
3. Put the DIP SWITCH 1 to OFF (DOWN) position to exit the code-learning mode.

(ONLY ONE FOUR BUTTON AND ONE KEYPAD CAN BE PROGRAMMED TO OPERATE THE SYSTEM)

CODE LEARNING (FOR KEYPAD TRANSMITTER)

NOTE: THE KEY PAD THAT COMES WITH THE SYSTEM IS ALREADY CODED.

To replace a lost or stolen transmitter please have the NEW keypad ready and follow the steps below.

(EACH KEYPAD HAS ITS OWN 4 DIGIT CODE NUMBER. MAKE SURE YOU HAVE THE 4 DIGIT CODE NUMBERS READY BEFORE INTO THE CODE LEARNING MODE).

1. Put the DIP SWITCH 1 to ON (UP) position. The parking will flash TWICE to indicate the module is in code learning mode.
2. Enter the 4-digit code then press 3/4 button on the keypad. The parking light will flash FOUR times to confirm the NEW code has been learned. If the parking light does not flash after inputting the 4-digit code and press the 3/4 button. These means the NEW code have not been learn. Please double check the codes and try again.
3. After the NEW code has been learned into the system. Put the DIP SWITCH 1 to OFF (DOWN) position to exit the code-learning mode.

TO CHANGE THE PIN CODE:

1. Press and hold the button 9/0 on the keypad for 3 seconds. The LED on button 9/0 will flash THREE times and the back ground light will flash TWICE very quick to confirm the module is now in code-learning mode.
2. Enter the OLD 4 digit user code, in the last digit press and hold for 2 second. If the OLD user code is correct, the LED light and background light on button 9/0 will flash ONCE. If the LED light and background light on button 9/0 flash TWICE to indicate the old user code is incorrect and will exit the code-changing mode.
3. Please repeat the steps above and try again.
4. Enter the NEW PIN code (3~7 digits), hold down the last digit for 2 seconds. If the NEW PIN code is accepted the LED light and background light on button 9/0 will flash ONCE to indicate the NEW PIN code is accepted. If the NEW PIN code is NOT accepted. The LED light and background light will flash TWICE to indicate the code is NOT accepting it. and exit the code changing code.
5. Enter the NEW PIN code (3~7 digits) again; hold down the last digit for 2 seconds to confirm the NEW CODE. If the NEW CODE is accepted the LED light and background light on button 9/0 will flash ONCE and turn OFF to indicate the NEW PIN code is accepted.
6. If the NEW PIN code is NOT accepting it. Please repeat the steps above and try again.
7. After the NEW PIN code has been accepted into the system. Please write down the NEW PIN code and keep it in a safe place. If the NEW PIN code is lost there is NOWAY to read the new pin code that your have enter to the system.

OPERATION MODE (WITH KEYPAD OPERATION)

- 1 Enter the 4 digit PIN code then press button 1/2 on the keypad momentarily. The module will send a signal to UNLOCK all the doors. The parking light will TWICE to confirm the operation
- 2 Enter the 4 digit PIN code then press button 3/4 on the keypad momentarily. The module will send a signal to LOCK all the doors. The parking light will flash ONCE to confirm the operation.
- 3 (A) Enter the 4 digit PIN code then press button 5/6 on the keypad momentarily. The module will send a negative signal to the YELLOW/BLACK wire on the harness to control an external relay.
(B) Enter the 4 digit PIN code then press and hold button 5/6 on the keypad. The module will send a continuous negative signal to the YELLOW/BLACK wire on the harness to control an external relay.

(THE SIGNAL WILL BE CONTINUOUS AS LONG AS THE BUTTON 5/6 IS PRESSED AND HELD DOWN)

- (C) Enter the 4 digit PIN code then press button 5/6 on the keypad momentarily. The module will send a LATCHED negative signal to the YELLOW/BLACK wire on the harness to control an external relay. This signal will stay LATCHED until you enter the 4 digit PIN code then press button 5/6 again to turn this signal OFF.

**(THE DIP SWITCH #3 MUST BE SET TO ON (UP) POSITION TO SELECT THIS OPERATION FUNCTION).
WARNING: IF THE OPERATION MODE IS SELECTED. MAKE SURE THIS CHANNEL IS TURNED OFF BEFORE LEAVING THE VEHICLE. FAILURE TO TURN OFF THIS FEATURE WILL RESULT IN A DEAD BATTERY UPON RETURN TO YOUR VEHICLE.**

- 4 (A) Enter the 4 digit PIN code then press button 7/8 on the keypad momentarily. The module will send a negative signal to the PURPLE wire on the harness to pop the trunk open or to control an external relay.
(ONLY IF THIS OPTION IS SELECTED. SOME VEHICLES MAY REQUIRE EXTRA PARTS AND LABOR. PLEASE SEE YOUR DEALER FOR DETAIL).
(B) Enter the 4 digit PIN code then press and hold button 7/8 on the keypad. The module will send a continuous negative signal to the PURPLE wire on the harness to control an external relay.

(THE SIGNAL WILL BE CONTINUOUS AS LONG AS THE BUTTON 7/8 IS PRESSED AND HELD DOWN)

- (C) Enter the 4 digit PIN code then press button 7/8 on the keypad momentarily. The module will send a LATCHED negative signal to the PURPLE wire on the harness to control an external relay. This signal will stay LATCHED until you enter the 4 digit PIN code then press button 7/8 again to turn this signal OFF.

**(THE DIP SWITCH #4 MUST BE SET TO ON (UP) POSITION TO SELECT THIS OPERATION FUNCTION).
WARNING: IF THE OPERATION MODE IS SELECTED. MAKE SURE THIS CHANNEL IS TURNED OFF BEFORE LEAVING THE VEHICLE. FAILURE TO TURN OFF THIS FEATURE WILL RESULT A DEAD BATTERY UPON RETURN TO YOUR VEHICLE.**

OPERATION MODE: (WITH FOUR BUTTONS REMOTE CONTROL)

1. Press button# 1 on the remote (**LOCK SYMBOL**) momentarily. The module will send a signal to LOCK all the doors.
The parking light will flash ONCE to confirm the operation.
- 2 Press button# 2 on the remote (**UNLOCK SYMBOL**) momentarily. The module will send a signal to UNLOCK all the doors.
The parking light will flash TWICE to confirm the operation.
- 3 (A) Press button# 3 on the remote (**TRUNK SYMBOL**) momentarily. The module will send a negative signal to the PURPLE wire on the harness to pop the trunk open or to control an external relay.
(ONLY IF THIS OPTION IS SELECTED. SOME VEHICLES MAY REQUIRE EXTRA PARTS AND LABOR. PLEASE SEE YOUR DEALER FOR DETAILS).
(B) Press and hold the button #3 on the remote . The module will send a continuous negative signal to the PURPLE wire on the harness to control an external relay.
(THE SIGNAL WILL BE CONTINUOUS AS LONG AS THE BUTTON IS HELD DOWN).
(THIS FEATURE IS NOT RECOMMENDED FOR TRUNK POP OPERATION).

(C) Press button# 3 on the remote (**TRUNK SYMBOL**) momentarily. The module will send a LATCHED negative signal to the PURPLE wire on the harness to control an external Relay. This signal will stay LATCHED until you press the #3 button on the remote again to turn it OFF.

(THE DIP SWITCH #4 MUST BE SET TO ON (UP) POSITION TO SELECT THIS OPERATION FUNCTION).

WARNING: IF THIS OPERATION MODE IS SELECTED. MAKE SURE THIS CHANNEL IS TURNED OFF BEFORE LEAVING THE VEHICLE. FAILURE TO TURN OFF THIS FEATURE WILL RESULT IN A DEAD BATTERY UPON RETURN TO YOUR VEHICLE.

- 4 (A) Press the * button on the remote momentary. The module will send a negative signal to the YELLOW/BLACK wire on the harness to control an external relay..
(B) Press and hold the * button on the remote. The module will send a continuous negative signal to the YELLOW/ BLACK wire on the harness to control an external relay.
(THE SIGNAL WILL BE CONTINUOUS AS LONG AS THE BUTTON IS HELD DOWN).
(C) Press the * button on the remote momentarily. The module will send a LATCHED negative signal to the YELLOW/BLACK wire to control an external relay.

(THE DIP SWITCH #3 MUST BE SET TO ON (UP) POSITION TO SELECT THIS OPERATION FUNCTION).

WARNING: IF THIS OPERATION MODE IS SELECTED. MAKE SURE THIS CHANNEL IS TURN OFF BEFORE LEAVING THE VEHICLE. FAILURE TO TURN OFF THIS FEATURE WILL RESULT IN A DEAD BATTERY UPON RETURN TO YOUR VEHICLE.

RS505 Wiring Diagram

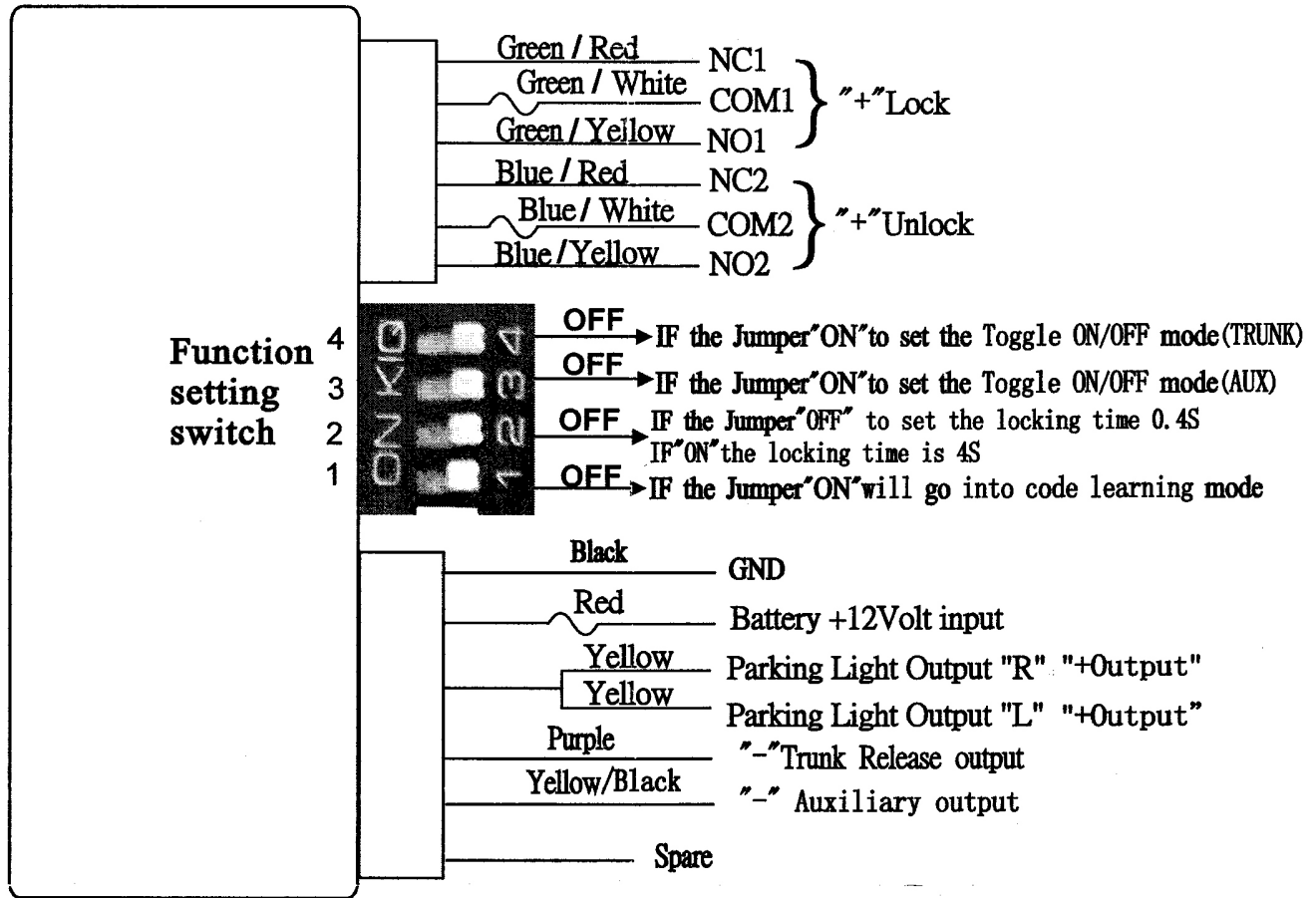

CENTRAL LOCK/UNLOCK INTERFACE

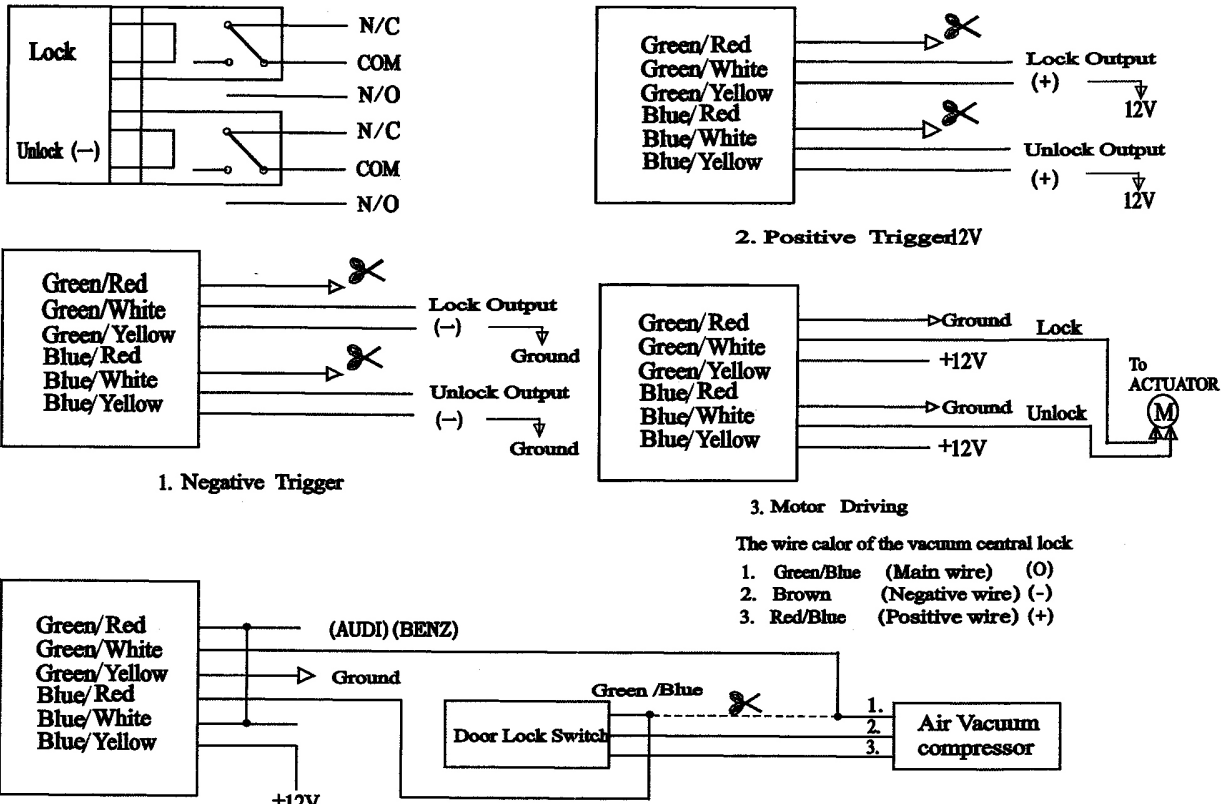

The wire color of the vacuum central lock

1. Green/Blue (Main wire) (0)
2. Brown (Negative wire) (-)
3. Red/Blue (Positive wire) (+)

P.S. The main wire will be switched to "Positive" & "Negative" Signal While unlock & lock