

## REAR-VIEW & VIM INTEGRATION w/ HANDLE & CAMERA FOR DODGE RAM 2013-UP

### RVCCH-75D



U-CONNECT 8.4" SCREEN  
 U-CONNECT 5" 6-BUTTON/ 2 KNOB  
 U-CONNECT 4.3" 6-BUTTON/ 2 KNOB

DODGE:  
 2013-2014 Ram

We recommend reading this installation guide first before starting any work. Following these instructions from "Start" to "Finish" will ensure a smooth and hassle free installation. We offer telephone support M-F 9:00 AM – 5:00PM PDT at 1 (855) 822-1348. We are here to help.

#### PARTS INCLUDED:

- (1) Tailgate Handle
- (1) Bullet Camera (CH-75D)
- (1) 15 ft. Extension
- (1) CH-75D Interface
- (1) CH-75D Harness
- (1) Instruction

#### Camera Specifications:

- Lens Angle 170 Degrees
- Resolution 420 TV Lines
- Min. Illumination 0.2Lux
- Voltage 12v
- Operating Temp. -22°F - 176°F
- NTSC
- Reference Lines
- Shutter Speed 1/60s - 20us
- Waterproof
- Pixels 656 x 492

#### PRECAUTIONS:

- Remove the negative side of the battery to avoid any short circuits during the installation.
- Do not install the interface near any major components or near the HVAC system. This may cause damage or overheating to the vehicle.

#### PRELIMINARY:

Please read the entire manual before installing this interface.

#### INSTALLING THE CAMERA AND CABLE

- Preliminary:** Insert the camera through the camera hole on the tailgate handle. Now proceed on to the removal of the factory handle.
1. Remove (8) T30 hex screws to remove the tailgate cover.
  2. Remove (2) 8mm screws to release the factory handle.
  3. Swap the key cylinder from the OE tailgate to the new one.
  4. Fish the wires through the tailgate and into the bottom of the truck's frame. Route towards the front of the vehicle. **Test camera angle.**
  5. Remove the factory radio to gain access to the factory connectors.
  6. Make the power and video then route the wires towards the radio and make the power connections connections. For powering up the camera, use the 12v OUTPUT (White Wire). (See Overview)

**Note: The camera is defaulted to power down after 10 seconds.**

#### FORCE REVERSE

The force reverse is used to view the back-up camera when the vehicle is not in reverse gear. Allows you to view what is in the back while driving.

To activate this feature make sure the dip switch settings are correct. Then simply **press the center button** once on the **Left Hand** steering wheel control.

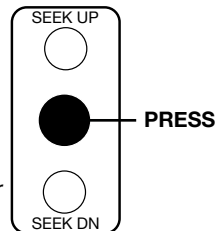

**Note: The camera is defaulted to power down after 10 seconds.**

**Make sure to test the camera angle before re-installing the tailgate cover.**

#### IMPORTANT:

Compatible Nav Radio Type:  
 U-CONNECT 8.4" SCREEN  
 U-CONNECT 5" 6-BUTTON/ 2 KNOB  
 U-CONNECT 4.3" 6-BUTTON/ 2 KNOB

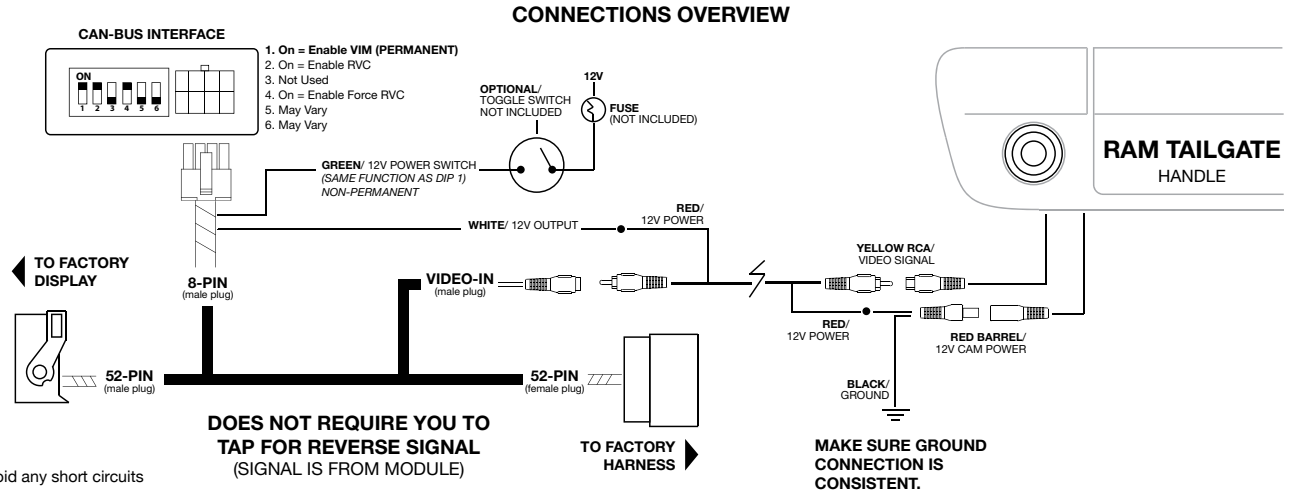

#### SETTING THE DIP SWITCHES

##### TO ENABLE VIDEO IN-MOTION

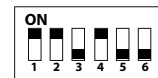

1. On = Enable VIM
2. On = Enable RVC
3. Not Used
4. On = Enable Force RVC
5. May Vary
6. May Vary

- Dip 1:** Activates the Video In-Motion feature. The dip switch is the permanent solution for keeping the VIM unlocked. Use the Green wire with a toggle switch for a non-permanent solution. (Switch not included)
- Dip 2:** Activates the Rear-View Camera image when the vehicle is in reverse gear.
- Dip 4:** Activates the "Force Rear-View Camera" while driving. Force Rear-View Camera allows the driver to view the rear-view camera when not in the Reverse gear.
- Dip 5 & 6:** Varies, these switches are defaulted both to OFF. If the radio is having turn-on issues please try the following:

- Attempt One: Set both 5 & 6 to the ON position.
- Attempt Two: Set 5 to On and 6 to OFF.
- Attempt Three: Set 5 to OFF and 6 to ON.

**If none of the above solutions work out for your vehicle please contact tech support.**

#### TROUBLE SHOOTING

1. No video display while in reverse.
  - Make sure the dip switches are in the correct position. More support contact us.

**MAKE SURE TO TEST THE CAMERA ANGLE BEFORE RE-INSTALLING THE TAILGATE COVER.**

#### PARKING LINE

The parking lines are there to assist you while reversing. What the lines mean:  
 Yellow Line: CLEAR  
 Purple Line: GETTING CLOSE  
 Red Line: WARNING - VERY CLOSE

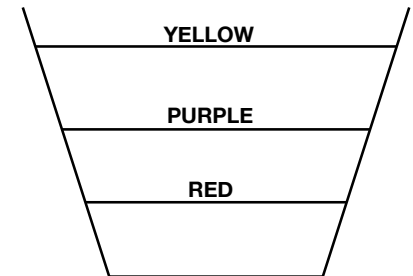

## REAR-VIEW & VIM INTEGRATION w/ HANDLE & CAMERA FOR DODGE RAM 2013-UP

RVCCH-75D



- U-CONNECT 8.4" SCREEN
- U-CONNECT 5" 6-BUTTON/ 2 KNOB
- U-CONNECT 4.3" 6-BUTTON/ 2 KNOB

**DODGE:**  
2013 -2014 Ram

### COMPATIBLE RADIOS:



**NOT COMPATIBLE RADIO  
DOES NOT SUPPORT COLOR**

Make sure to test the camera angle before re-installing the tailgate cover.

**IMPORTANT:**  
Compatible Nav Radio Type:  
U-CONNECT 8.4" SCREEN  
U-CONNECT 5" 6-BUTTON/ 2 KNOB  
U-CONNECT 4.3" 6-BUTTON/ 2 KNOB