

ALL VEHICLES

1

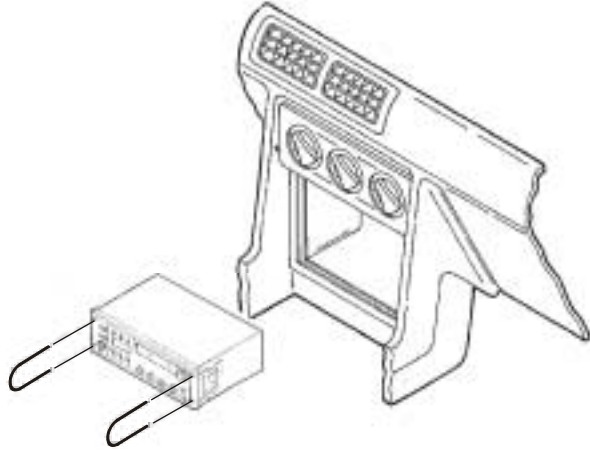

Disconnect the negative battery terminal to prevent an accidental short circuit. Using Metra's **86-5618**, pull the factory head unit from the dash and disconnect the wiring.

2

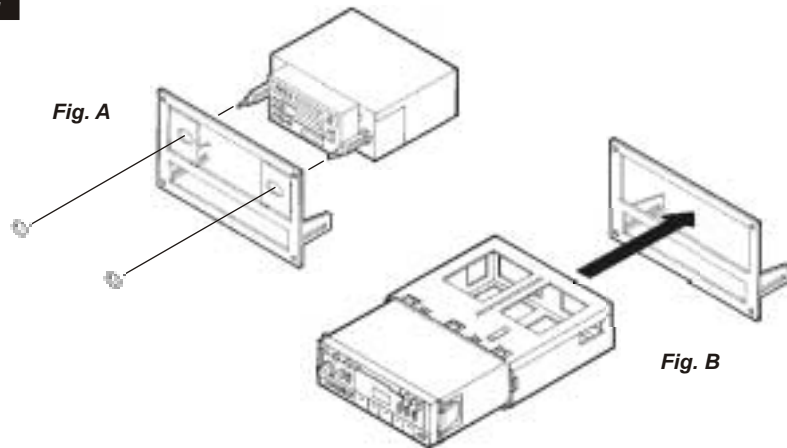

2-SHAFT HEAD UNITS: Slide the aftermarket head unit into the kit and secure with shaft nuts. (see Fig. A)

DIN HEAD UNITS: Cut and remove the shaft supports from the **Radio Housing**. Slide the DIN cage into the Housing and secure by bending the metal locking tabs down. Slide the aftermarket head unit into the cage until secure. (see Fig. B)

3

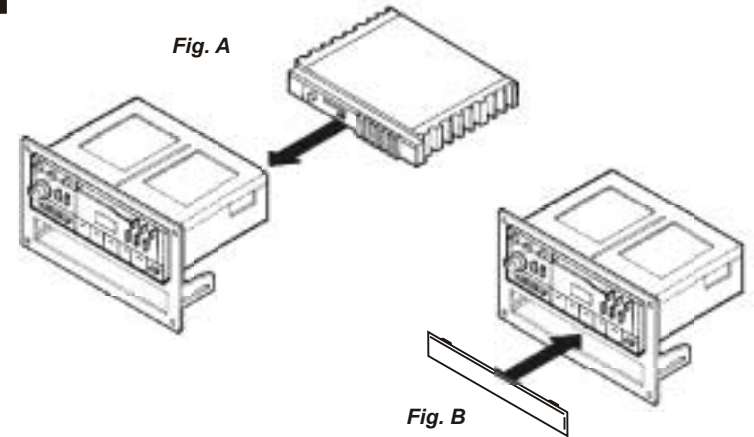

IF AN EQUALIZER WILL BE INCLUDED: Slide the aftermarket equalizer into the back of the **Radio Housing**. Using the hardware included with the equalizer, mount the unit to the kit. (see Fig. A)

IF AN EQUALIZER WILL NOT BE INCLUDED: Snap the **Equalizer Dummy Plate** into the **Radio Housing**. (see Fig. B)

4

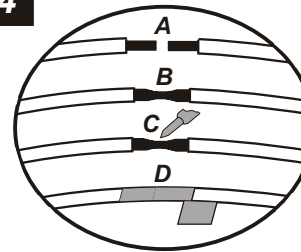

A) Strip wire ends back 1/2"
B) Twist ends together
C) Solder
D) Tape

Locate the factory wiring harness in the dash. Metra recommends using the proper mating adaptor and making connections as shown. (Isolate and individually tape off the ends of any unused wires to prevent electrical short circuit).

5



Re-connect the battery terminal and test the unit for proper operation. Mount the **Rear Support Bracket** to the back of the unit. Mount the head unit/kit assembly to the sub-dash with **(4) Phillips Oval-head Screws** supplied. (Be sure the Rear Support Bracket engages the support shelf in the dash).

KIT FEATURES

- ▶ Shaft and DIN unit provisions
- ▶ Equalizer provisions

KIT COMPONENTS

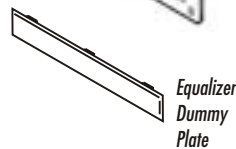
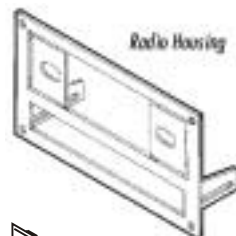

TOOLS REQUIRED



86-5618 - Head unit removal keys



Phillips screwdriver



Cutting tool

99-5025

INSTALLATION INSTRUCTIONS

APPLICATIONS

CAR	PAGE
FORD	
Mustang 1987-93.....	1-2

